

# Rental price list / Dry hire price list

Rental and sales for  
event technics, Audioequipment, Loudspeakers,  
Lightequipment,  
AV- & Mediaequipment, Photoboxes



**Weddings, Companyevents, Presentations, Catwalks,  
Conferencing, Fair / Exhibition / Trade Fair, Bandgigs, Partys,  
Concerts, Partytrucks & Demotruck equipment a.s.o.**

## Theimer und Mager Eventequipment

Libellenweg 81

60529 Frankfurt am Main

E-Mail. [info@theimerundmager.de](mailto:info@theimerundmager.de)

**Save money at our special offers, these offers are only able to book in our rentshop!**

Rentshop 24/7. [www.theimerundmager.de/shop](http://www.theimerundmager.de/shop)

Tel. +49 - (0)69 - 66 16 35 16

Fax. +49 - (0)69 - 66 16 35 17

Web / Homepage. [www.theimerundmager.de](http://www.theimerundmager.de)

### Warehouse opening times

Monday	7 p.m. – 9 p.m.
Tuesday	closed
Wednesday	closed
Thursday	8 p.m. – 10 p.m.
Friday	7 p.m. – 9 p.m.

**Other times could be possible on request.**

Find **all important details** like:

- Rental price lists
- Manuals
- Manuals for build up Sound- & Lightequipment
- News
- **Current offers** for example for **Weddings, Fair materials, Conference equipment...**
- Rental consultants

On our Homepage

[www.theimerundmager.de](http://www.theimerundmager.de)

or in our  
**Rentshop**

[www.theimerundmager.de/shop](http://www.theimerundmager.de/shop)

As a registered customer, you will also get the current disposition of our rental articles and you could send us directly your request free of charge by mail.

Special offers are also integrated and could only be booked at the rentsshop.

Our  
"**Audio system rental consultant**"  
and our  
"**Audio player consultant**"

could help you to find the perfect soundequipment for your event.

## Company history

We are working in the sector of rental of professional rental equipment for events for loudspeaker systems, light equipment and AV- & Mediatechnical equipment since the 15.09.2003. With the conversion 2005 from rental up to added on sale of professional public address audio and light equipment, as well av- & mediatechnics, we always upgraded our rental pool to the requests of our costumers. You have not only got the chance to rent needed equipment for your event, you also got the possibility, that we offer you equipment for sale for convenient prices.

Since beginning of the year 2020, we choosed the producer LD Systems and RCF, not only because of the high flexibility for us and for our customers, but also by reason of quality of sound, weightness and handling pros of this sound systems.

As well you could find products for rental of companys like Pioneer and Technics for high level DJing, also Mackie and X32 Variations for professional technicians and bands, wich could be perfectly used with soundsystems.

Shure ® microphones promise a wonderful all-round application and best soundquality for your event. To get the glamorous brilliance of lights to your event, we offer products of Ape Labs. There is no event impression without lights possible.

If you should need meeting equipment, we offer different kind of projectors and associated rollup screens, to facilitate your meetingdays.

For sure, you will find all new updates and informations on our homepage

[www.theimerundmager.de](http://www.theimerundmager.de), so if you like, you could stop by, it could be profitable for you.

It would be a great pleasure for use to work with you together. Do not hessitate to contact us, we always try to plan your event with you together, as good as it could be possible.

Please note, that the reduced rental prices from Warehouse, got no back up materials with.

The listed prices are only for emission and return by yourself, as well we give a short instruction to you at emission (by setted times and dates before). Normaly we charge the mentioned prices for 1-day use by 24 hours. If we got the possibility and the dispositions, we only charge the day of use and give you for a free charge the option, that you could hold the equipment for a longer time.

For this option, it is necessary, that all dates and times are arranged with us before.

Most of the devices (equipment) in this price list are more than one times available!

### **All prices are netto, the VAT will be charged as well**

Build up manualsare available, you could find them:

-> on our Homepage under:

[www.theimerundmager.de](http://www.theimerundmager.de)

Downloads

Build up manuals



### **Living on a smarter Planet**

Have a look on our "**EnergySaver**" **Symbol**. With Energy saving lamps at the same or more power output, or to work with digital equipment with more power with the same or less input power, generates sustained yield and takes care to graduate the natural resources of our planet.

INDEX

<b>1. SOUND EQUIPMENT .....</b>	<b>6</b>
1.1. ACTIVE CABINETS WITH BATTERY (ACTIVE CABINET SPEAKER BATTERYCHARGED).....	6
1.2. ACTIVE CABINETS (ACTIVE CABINET SPEAKER) .....	6
1.3. LINE ARRAY - ACTIVE (LINE ARRAY MODULES, FRAME`S, BRIDLE).....	9
1.4. MIXER (CLUB / LIVE / MONITOR / DIGITAL / FOH).....	12
1.5. PLAYER (CD PLAYER, TURNTABLES, KARAOKE PLAYER).....	17
1.6. DELAY`S CONTROLLER.....	19
1.7. MIKROPHONES.....	20
1.8. ADD ON`S (STANDS, DI BOXES, LINE-ISOLATORS, ANALOG & DIGITAL MULTICORES, STAGEBOXES, AUDIOCABLES AND -ADAPTER, WIRELESS SIGNAL BROADCAST).....	28
1.9. AUDIO SETS .....	38
<b>2. LIGHT EQUIPMENT .....</b>	<b>42</b>
2.1. AKKU (RECHARGEABLE BATTERY)S LED LAMPS (APE LABS, ASTERA).....	42
2.2. HEAD LAMPS / FLUTER / CHASER / PAR LED LAMPS / LED BARS .....	47
2.3. DANCE LIGHT EFFECTS / CLASSIC DISCOEFFECTS / LED EFFECTS / LASER.....	48
2.4. CONTROLLER (SWITCHES, DIMMER, LIGHTCONTROLLER, SIGNAL CABLES, WIRELESS DMX).....	50
2.5. SHOEFFECTS.....	54
2.6. ADDON (STANDS, FLOORSTANDS, STANDSETS) .....	54
2.7. LIGHT SETS .....	55
<b>3. AV- &amp; MEDIATECHNICS .....</b>	<b>57</b>
3.1. PROJECTORS, SCREENS, DISPLAYS, SPLITTER .....	57
3.2. AV- & MEDIATECHNICS SETS.....	62
3.3. PHOTOBox / FOTOBox / PHOTOBOOTH .....	62
3.4. LIVESTREAM & BROADCASTING, VIDEOCAMERAS, VIDEO CAPTURING.....	63
<b>4. RIGGING (TRUSSING &amp; ADDON`S).....</b>	<b>64</b>
4.1. LIFTING ACCESSORIES (HOOKS, SHAKLE, ROBES, SAFETY HARNESS, TV GUDGEONAND SO ON...).....	64
4.2. TRUSSING (GLOBAL TRUSS) .....	66
4.3. STAGE MATERIALS (CABLE MATTRESS, TENTS, AND SO ON...).....	67
4.4. SYSTEMPLATFORM (NIVTEC) .....	69
<b>5. ELECTRICITY POWER, ENERGY &amp; GENERATORS.....</b>	<b>70</b>
5.1. THREE-PHASE CURRENT POWER (CEE) & GROUNDING-TYPES (THREE-PHASE CURRENT-, GROUNDING-TYPES -, PERFORMANCE LOAD MULTICORECABLE-, CABLES & DISTRIBUTORS) .....	70
<b>6. TOOLS.....</b>	<b>73</b>
6.1. TOOLS .....	73
<b>7. SERVICE.....</b>	<b>74</b>
7.1. TECHNICANS, DJs, LONG TERM RENTALS .....	74

# 1. Sound Equipment

## 1.1. Active Cabinets with battery (active cabinet speaker batterycharged)

LD Systems MAUI 5 GO	
<b>Producer</b>	LD Systems
<b>Series</b>	MAUI
<b>Description</b>	5 GO
<b>Type</b>	Fullrange
<b>Listener (Pax)</b>	Max. 50
<b>RMS Power</b>	200
<b>Build up manual</b>	No (-)
<b>Cargocapacity</b>	Compact car



1 \* 8 Zoll Subwoofer  
 1 \* 4\*3" Satellite loudspeakers  
 Inputs: 1 \* XLR mono (Mic), 2 \* XLR mono (ext.mixer), 1 \* 6,35mm Jack (Guit.); incl. integrated Mixer and 2 \* distance spacer (1 with battery); Output: 1 \* XLR (mono); packed in two easy handled Transport bags; **Bluetooth on Board**

**60 €**



## 1.2. Active Cabinets (active cabinet speaker)

LD Systems MAUI 5	
<b>Producer</b>	LD Systems
<b>Series</b>	MAUI
<b>Description</b>	5
<b>Type</b>	Fullrange
<b>Listener (Pax)</b>	Max. 50
<b>RMS Power</b>	200
<b>Build up manual</b>	No (-)
<b>Cargocapacity</b>	Compact car



1 \* 8 Zoll Subwoofer  
 1 \* 4\*3" Satellite loudspeakers  
 Inputs: 1 \* XLR mono (Mic), 2 \* XLR mono (ext.mixer), 1 \* 6,35mm Jack (Guit.); incl. integrated Mixer and 2 \* distance spacer packed in two easy handled Transport bags; **Bluetooth on Board; batterycharged; could also be used on a normal powerplug**

**50 €**





RCF Evox JMix8	
<b>Producer</b>	RCF
<b>Series</b>	Evox
<b>Description</b>	JMix8
<b>Type</b>	Fullrange
<b>Listener (Pax)</b>	Max. 80
<b>RMS Power</b>	700
<b>Build up manual</b>	No (-)
<b>Cargocapacity</b>	Compact car







1 \* 12 Zoll Subwoofer  
 1 \* 8\*2"/1" Satellite loudspeakers  
 Inputs: 4 \* Microphone XLR Combined Connector; 2 \* 6,35mm Jack; 1 \* Cinch; incl. integrated Mixer and distance row packed in a easy handled Transport Trolley; Smartphone connection cable; App available; **Bluetooth on Board**

**65 €**



<b>LD Systems Stinger 2.1</b>				
<b>Producer</b>	LD Systems		1 * 15 Zoll Subwoofer 2 * 10 Zoll Satellite loudspeakers Inputs: XLR Including stands	<b>60 €</b>
<b>Series</b>	Stinger			
<b>Description</b>	2.1			
<b>Type</b>	Fullrange			
<b>Listener (Pax)</b>	Max. 150			
<b>RMS Power</b>	1050			
<b>Build up manual</b>	No (-)			
<b>Cargocapacity</b>	Compact car			

<b>LD Systems Stinger 10 A G3 / Multifunktional Top System / Stage Monitor</b>				
<b>Producer</b>	LD Systems		10 Zoll XLR 2 * In / 1 * Out Stand muff available	<b>20 €</b>
<b>Series</b>	Stinger			
<b>Description</b>	10 A G3			
<b>Type</b>	Satellite			
<b>Listener (Pax)</b>	Max. 50		Inputs are separate switchable to microphone or line	
<b>RMS Power</b>	300			
<b>Build up manual</b>	No (-)			
<b>Cargocapacity</b>	Compact car			
			Monitorwedge included	
			4 modes of playback: Full-Range, Satellite, Monitor, Flat	
			Flightclamp available for 1,- €	

<b>LD Systems Stinger 12 A G3 / Multifunktional Top System / Stage Monitor</b>				
<b>Producer</b>	LD Systems		12 Zoll XLR 2 * In / 1 * Out Stand muff available	<b>22,5 €</b>
<b>Series</b>	Stinger			
<b>Description</b>	12 A G3			
<b>Type</b>	Satellite			
<b>Listener (Pax)</b>	Max. 75		Inputs are separate switchable to microphone or line	
<b>RMS Power</b>	500			
<b>Build up manual</b>	No (-)			
<b>Cargocapacity</b>	Compact car			
			Monitorwedge included	
			4 modes of playback: Full-Range, Satellite, Monitor, Flat	
			Flightframe available for 8,- €	

<b>LD Systems Stinger Sub 15 A G3</b>				
<b>Producer</b>	LD Systems		1 * 15 Zoll XLR 2 * In / 2 * Out M20-winding for distance pipe	<b>20 €</b>
<b>Series</b>	Stinger			
<b>Description</b>	Sub 15 A G3			
<b>Type</b>	Subwoofer			
<b>Listener (Pax)</b>	Max. 75		Dolly for transport included	
<b>RMS Power</b>	450			
<b>Build up manual</b>	No (-)			
<b>Cargocapacity</b>	Compact car			
			4 Frequency switches: 80Hz, 100Hz, 120Hz, Cardioid	

<b>RCF Sub 8004-AS Hochleistungssubwoofer</b>	
<b>Producer</b>	RCF
<b>Series</b>	Pro Sound Sub Series
<b>Description</b>	8004-AS
<b>Type</b>	Subwoofer
<b>Listener (Pax)</b>	Max. 500
<b>RMS Power</b>	1250
<b>Build up manual</b>	Nein (-)
<b>Cargocapacity</b>	Kombi



1 \* 18 Zoll  
XLR 1 \* In / 2 \* Out (Link & XOver)  
M20-winding for distance pipe  
on top and at the side

3 Frequency switches:  
90Hz, 120Hz, Cardioid

Delay, DSP

136 dB max SPL

**40 €**



<b>LD Systems Stinger - Set 1215-2.2</b>	
<b>Producer</b>	LD Systems
<b>Series</b>	Stinger
<b>Description</b>	Set 1215-2.2 Fullrange
<b>Musictype</b>	
<b>Listener (Pax)</b>	Max. 250
<b>RMS Power</b>	1900
<b>Build up manual</b>	Yes (☑)
<b>Cargocapacity</b>	Stationwagon



2 \* LD Systems Stinger 12 A G3  
2 \* LD Systems Stinger Sub 15 A  
G3

XLR In / Out

Including needed cables and  
distance pipe

Digitalamping for ultimative clear &  
accurate sound!

**85 €**



<b>LD Systems Stinger - Set 1215-2.4</b>	
<b>Producer</b>	LD Systems
<b>Series</b>	Stinger
<b>Description</b>	Set 1215-2.4 Fullrange
<b>Musictype</b>	
<b>Listener (Pax)</b>	Max. 350
<b>RMS Power</b>	2800
<b>Build up manual</b>	Yes (☑)
<b>Cargocapacity</b>	Stationwagon / Van



2 \* LD Systems Stinger 12 A G3  
4 \* LD Systems Stinger Sub 15 A  
G3

XLR In / Out

Digitalamping for ultimative clear &  
accurate sound!

Including needed cables and  
distance pipe

You are able to set Cardioid by  
turning the subs.

The sub frequencys will be  
terminated behind the speaker  
tower to get more quiet stages.

**125 €**



## 1.3. Line Array - active (Line Array modules, Frame`s, Bridle)



### Function of a Line Array (Source: www.Wikipedia.de search "Line Array")

"...A line array is a loudspeaker system that is made up of a number of usually identical loudspeaker elements mounted in a line and fed in phase, to create a near-line source of sound. The distance between adjacent drivers is close enough that they constructively interfere with each other to send sound waves farther than traditional horn-loaded loudspeakers, and with a more evenly distributed sound output pattern.

Line arrays can be oriented in any direction, but their primary use in public address is in vertical arrays which provide a very narrow vertical output pattern useful for focusing sound at audiences without wasting output energy on ceilings or empty air above the audience. A vertical line array displays a normally wide horizontal pattern useful for supplying sound to the majority of a concert audience. Horizontal line arrays, by contrast, have a very narrow horizontal output pattern and a tall vertical pattern. A row of subwoofers along the front edge of a concert stage can behave as a horizontal line array unless the signal supplied to them is adjusted (delayed, polarized, equalized) to shape the pattern otherwise. Loudspeakers can be designed to be arrayed horizontally without behaving as a horizontal line source.

Modern line arrays use separate drivers for high-, mid- and low-frequency passbands. For the line source to work, the drivers in each passband need to be in a line. Therefore, each enclosure must be designed to rig together closely to form columns composed of high-, mid- and low-frequency speaker drivers. Increasing the number of drivers in each enclosure increases the frequency range and maximum sound pressure level, while adding additional boxes to the array will also lower the frequency in which the array achieves a directional dispersion pattern.

The large format line array has become the standard for large concert venues and outdoor festivals, where such systems can be flown (rigged, suspended) from a structural beam, ground support tower or off a tall A-frame truss tower. Since the enclosures rig together and hang from a single point, they are more convenient to assemble and cable than other methods of arraying loudspeakers. The lower portion of the line array is generally curved backward to increase dispersion at the bottom of the array and allow sound to reach more audience members. Typically, cabinets used in line arrays are trapezoidal, connected by specialized rigging hardware..."

RCF (D-Line) HDL 10-A Line Array module			
<b>Producer</b>	RCF		
<b>Series</b>	D-Line		
<b>Description</b>	HDL 10-A		
<b>Type</b>	Line Array		
<b>Listener (Pax)</b>	Max. 187		
<b>RMS Power</b>	700		
<b>Build up manual</b>	No		
<b>Cargocapacity</b>	Van / Transporter		
		2*8 Zoll / 1*2 Zoll XLR In / Out PowerCon In / Out  Weight: 20,4 kg Frequency: 65-20.000 Hz SPL: 133 db max.  Angle of radiation: Horizontal: 100° Vertical: 15°  2* QuicklockPin Front 1* QuicklockPin Back 2* Raincover Back	<b>35 €</b>

RCF (D-Line) HDL 10-A Frame / Bridle FlyBar LIGHT			
<b>Producer</b>	RCF	Frame / Bridle FlyBar LIGHT	
<b>Series</b>	D-Line	Included parts:	
<b>Description</b>	Light Frame	7* QuicklockPin Frame 2* Stackbar Front 1* Stackbar Back 1* Pickpoint 1* Trussmount Adapter 1* Polemount Adapter 1* Polemount NXL (1* short & 1* long) 1* Steelflex 1* Shakle	
<b>Type</b>	Riggingframe Stackframe		
<b>Rigging</b>	Max. 6* HDL 10-A		
<b>Groundstack</b>	Max. 1* HDL 10-A		
<b>Build up manual</b>	No		
<b>Cargocapacity</b>	Van / Transporter		
			
			<b>20 €</b>

RCF (D-Line) HDL 10-A Frame / Bridle FlyBar		
<b>Producer</b>	RCF	Frame / Bridle FlyBar
<b>Series</b>	D-Line	Included parts:
<b>Description</b>	Light Frame	3* QuicklockPin Frame 1* Stackbar Back 1* AC Connection Bracket M20 1* Pickpoint 1* Steelflex 1* Shakle
<b>Type</b>	Riggingframe Stackframe	
<b>Rigging</b>	Max. 16* HDL 10-A	
<b>Groundstack</b>	Max. 4* HDL 10-A	
<b>Build up manual</b>	No	
<b>Cargocapacity</b>	Van / Transporter	
		
		<b>20 €</b>

Set - Line Array (Groundstack)			
4* HDL 10-A, 2* 8004-AS			
<b>Producer</b>	RCF		4 * RCF HDL 10-A Line Array Modules 2 * RCF 8004-AS Subwoofer 2 * Frame / Bridle FlyBar and distance poles Including power and signal cables <b>250 €</b>  16 A CEE Powerplug needed!
<b>Series</b>	D-Line		
<b>Description</b>			
<b>Type</b>	Fullrange		
<b>Listener (Pax)</b>	Max. 750		
<b>RMS Power</b>	5300		
<b>Build up manual</b>	No (-)		
<b>Cargocapacity</b>	Transporter		

Set - Line Array (Groundstack)			
8* HDL 10-A, 4* 8004-AS			
<b>Producer</b>	RCF		8 * RCF HDL 10-A Line Array Modules 4 * RCF 8004-AS Subwoofer 2 * Frame / Bridle FlyBar Including power and signal cables <b>500 €</b>  32 A CEE Powerplug needed!
<b>Series</b>	D-Line		
<b>Description</b>			
<b>Type</b>	Fullrange		
<b>Listener (Pax)</b>	Max. 2000		
<b>RMS Power</b>	10600		
<b>Build up manual</b>	No (-)		
<b>Cargocapacity</b>	Transporter		

## 1.4. Mixer (Club / Live / Monitor / Digital / FOH)

Behringer DX 626	
<b>Producer</b>	Behringer
<b>Series</b>	DX
<b>Description</b>	626
<b>Type</b>	Mixer
<b>Type of usage</b>	DJ
<b>Channels Input</b>	3
<b>Effectsection</b>	No (-)
<b>Microphonechannel</b>	Yes (1)
<b>Cargocapacity</b>	Compact car



**3 Channels:**  
 1 Phono / 1Line  
 1 Phono / 1Line  
 1 Micro XLR / 1 Phono or 1 Line

**Outputs:**  
 1 Cinch (Master)  
 1 Cinch (Record)

Crossfader  
 BPM Counter

**7,5 €**

Pioneer DJM 700	
<b>Producer</b>	Pioneer
<b>Series</b>	DJM
<b>Description</b>	700
<b>Type</b>	Mixer
<b>Type of usage</b>	DJ
<b>Channels Input</b>	4
<b>Effectsection</b>	Yes
<b>Microphone channel</b>	Yes(2)
<b>Cargocapacity</b>	Compact car



**4 Channels:**  
 1 Line / 1Line  
 1 Phono / 1 Line  
 1 Phono / 1 Line  
 1 Phono / 1 Line  
 1 Micro XLR / 1 Micro Jack

**Outputs:**  
 1 Cinch / XLR (Master)  
 1 Cinch (Booth)  
 1 Cinch (Record)  
 1 Jack (Effect Send)  
 1 Jack (Effect Return)  
 1 Digital Out  
 1 Midi Out

Crossfader& Fader Curve  
 BMP Counter  
 Player Control (Ch1 + CH2)  
 Effect Processor  
 Fader Curve

**22,5 €**

Pioneer DJM 750 MK II - K	
<b>Producer</b>	Pioneer
<b>Series</b>	DJM
<b>Description</b>	750 MK II K
<b>Type</b>	Mischpult
<b>Type of usage</b>	DJ
<b>Channels Input</b>	4

**4 channels:**  
 1 Phono / 1 Line  
 1 Phono / 1 Line  
 1 Phono / 1 Line  
 1 Phono / 1 Line  
 1 Mikro XLR

<b>Effectsection</b>	Yes		<b>Outputs:</b>	<b>30 €</b>
<b>Microphone channel</b>	Yes (1)		1 Cinch / XLR (Master)	
<b>Cargocapacity</b>	Compact car		1 6,35mm Jack (Booth) 1 Cinch (Record) 1 Jack (Effect Send) 1 Jack (Effect Return)	
			Beat FX	

Pioneer DJM 900 Nexus 2				
<b>Producer</b>	Pioneer		<b>4 channels:</b>	<b>65 €</b>
<b>Series</b>	DJM		1 Phono / 1 Line	
<b>Description</b>	900 Nexus 2		1 Phono / 1 Line	
<b>Type</b>	Mixer		1 Phono / 1 Line	
<b>Type of usage</b>	DJ		1 Phono / 1 Line	
<b>Channels Input</b>	4		1 Microphone Jack / XLR CombIn	
<b>Effectsection</b>	Yes		1 Microphone Jack	
<b>Microphone channel</b>	Yes(2)		4 Digital In	
<b>Cargocapacity</b>	Compact car		<b>Outputs:</b>	
			1 XLR (Master 1)	
			1 Cinch (Master 2)	
			1 Jack (Booth)	
			1 Cinch (Record)	
			1 Jack (Effect Send)	
			1 Jack (Effect Return)	
			1 Digital Out	
			1 Ethernet Link	
			Beat FX	
			SOUND COLOR FX	
			Frequence Effects	
			USB-Soundcard 4 (Stereo In / 5	
			Stereo Out) with A/B change	
			Crossfader & Fader Curve	
			Recordbox dvs	
			Traktor DVS, Serato DJ Pro, Show	
			Kontrol, DJM-Rec - Compatible	

Mackie PROFX8v2			
<b>Producer</b>	Mackie		<b>Inputs:</b>
<b>Series</b>	ProFX		4* 1 Mono XLR / Jack & Insert St.
<b>Description</b>	8v2		Jack
<b>Type</b>	Mixer		1* 1 Stereo / 2 Jack
<b>Type of usage</b>	Live		1 Cinch Tape In



<b>Channels Input</b>	6		<b>Outputs:</b>	<b>22,5 €</b>
<b>Effectsection</b>	Yes		1 XLR / Jack (Master Stereo)	
<b>Microphone channel</b>	Yes (4)		1 Cinch Tape Out	
<b>Cargocapacity</b>	Compact car		1 Jack Aux Way Send	
			1 Jack Effect Way Send	
			48V Phantomfeeding	
			digital Effectsection with 16	
			Programms	
			7 Band Stereo EQ	

LD Systems VIBZ 8 DC				
<b>Producer</b>	Mackie		<b>Inputs:</b>	
<b>Series</b>	ProFX		4* 1 Mono XLR / Jack & Insert St.	
<b>Description</b>	8v2		Jack (2 channels with Compressor)	
<b>Type</b>	Mixer		1* 1 Stereo / 2 Jack or 2 Cinch	
<b>Type of usage</b>	Live		1 Cinch Tape In	
<b>Channels Input</b>	6			
<b>Effectsection</b>	Yes			
<b>Microphone channel</b>	Yes (4)			
<b>Cargocapacity</b>	Compact car			
			<b>Outputs:</b>	<b>22,5 €</b>
			1 Jack (Master Stereo)	
			1 Cinch Tape Out	
			1 Jack Aux Way Send	
			1 Jack Effect Way Send	
			48V Phantomfeeding	
			digital Effectsection with 10	
			Programms	

Behringer X32 - Compact				
<b>Producer</b>	Behringer		<b>Inputs:</b>	
<b>Series</b>	X32		16* Mono XLR	
<b>Description</b>	Compact			
<b>Type</b>	Digital-mixer		4 / 6 Insert (Aux channel 1-4,5+6)	
			1 Stereo Cinch (Aux channel 5+6)	

<b>Type of usage</b>	Live / FOH		1 Midi In	<b>70 €</b>
<b>Channels Input</b>	16		<b>Outputs:</b>	
<b>Effectsection</b>	Yes		8 XLR	
<b>Microphone channel</b>	Yes (16)		4 / 6 Insert (Aux channel 1-4,5+6)	
<b>Cargocapacity</b>	Station Wagon		1 Stereo Cinch (Aux channel 5+6)	
			2 FOH Monitor XLR / 6,35mm Jack	
			2 AES50 RJ45 Multicore	
			1 AES/EBU	
			1 Ultramet (Pers. Monitoring)	
			1 Midi Out	
			1 USB 2.0 für 32x In/Out	
			1 RJ45 Remote Control	
			48V Phantompower for each channel	
			4 Band EQ	
			Compressor / Gate	
			Effects	
			100mm Motor Fader	
			Recording to a USB Stick	
			Talkback microphone included	
			Desk lamp included	

Behringer X32			
<b>Producer</b>	Behringer	<b>Inputs:</b>	
<b>Series</b>	X32	<b>32*</b> Mono XLR	
<b>Description</b>	Fullsize		
<b>Type</b>	Digital-mixer	4 / 6 Insert (Aux channel 1-4,5+6)	
		1 Stereo Cinch (Aux channel 5+6)	

<b>Type of usage</b>	Live / FOH	  	1 Midi In	<b>95 €</b>
<b>Channels Input</b>	32		<b>Outputs:</b>	
<b>Effectsection</b>	Yes		16 XLR	
<b>Microphone channel</b>	Yes (32)		4 / 6 Insert (Aux channel 1-4,5+6)	
<b>Cargocapacity</b>	Station Wagon		1 Stereo Cinch (Aux channel 5+6)	
			2 FOH Monitor XLR / 6,35mm Jack	
			2 AES50 RJ45 Multicore	
			1 AES/EBU	
			1 Ultramet (Pers. Monitoring)	
			1 Midi Out	
			1 USB 2.0 für 32x In/Out	
			1 RJ45 Remote Control	
			48V Phantompower for each channel	
			4 Band EQ	
			Compressor / Gate	
			Effects	
			100mm Motor Fader	
			Recording to a USB Stick	
			Talkback microphone included	
			Desklamp included	

Numark HF-125				
<b>Producer</b>	Numark		Frequency: 20 - 20000 Hz	<b>3 €</b>
<b>Series</b>	HF		Cable: 2,0 m	
<b>Description</b>	125		Weight: 180 g	
<b>Type</b>	Earphones			
<b>Type of usage</b>	DJ / FOH			
<b>Cargocapacity</b>	Bag			

## 1.5. Player (CD Player, Turntables, Karaoke Player)

Philips Bluetooth Empfänger	
<b>Producer</b>	Philips
<b>Series</b>	-
<b>Description</b>	-
<b>Type</b>	Receiver for mobile device
<b>CD Format</b>	No (-)
<b>MP3 CD Format</b>	No (-)
<b>USB</b>	No (-)
<b>Deckversion</b>	-
<b>Cargocapacity</b>	Compact car



For a wireless playback from your Smartphone / Tablet on a PA System.

The Receiver must be connected with a audio mixer, to realize the playback function. The Receiver will be rent with a power connector and a cinch cable.

**5 €**

Notebookconnectionset	
<b>Producer</b>	-
<b>Series</b>	-
<b>Description</b>	-
<b>Type</b>	Connection for Notebook
<b>CD Format</b>	No (-)
<b>MP3 CD Format</b>	No (-)
<b>USB</b>	No (-)
<b>Deckversion</b>	-
<b>Cargocapacity</b>	Compact car



The Set contains the following components, to connect a Notebook / IPod / Smartphone / Tablet with a PA System:

- 1x 3,5mm Jack Adapter to Cinch
- 2x Cinch cables
- 1x Palmer Line Isolator

The Set must be connected with a audio mixer, to realize the playback function.

**5 €**

LD Systems CDMP1 Mediaplayer	
<b>Producer</b>	LD Systems
<b>Series</b>	CDMP
<b>Description</b>	1
<b>Type</b>	Media Player
<b>CD Format</b>	Yes
<b>MP3 CD Format</b>	Yes
<b>USB</b>	Yes (Fat32)
<b>Deckversion</b>	Singledeck
<b>Cargocapacity</b>	Compact car





Singledeck with CD / MP3 / USB (FAT32) / SD-Karte



Outputs:

- 1x Stereo (Cinch)
- 2x XLR

**20 €**

Sunfly Pro-009 / Madboy MFP-1500 Karaoke Player		
<b>Producer</b>	Sunfly	<div style="display: flex; align-items: center;">  <div style="flex-grow: 1;"> <p>Multiformat Player with playback for different medias and Karaoke-datas, including DVD, MP3+G, CD+G, CD, XVID, MP4, AVI, VCD, MPEG-1, MPG-2, DivX 4.12, DivX 5.02, DivX 5.11, DivX 5.20, DivX 5.21, DivX 6.0, DAT, JPG Compatibility</p> <p>You could convert CD+Gs into digital MP3+Gs and save them to USB or SD Card</p> <p><b>60 €</b></p> <p>Audio Outputs:            1x 5.1 Channel Surround Sound (Cinch)            1x Stereo (Cinch)            1 x Karaoke (Cinch)            1x Coaxial            1x Optical</p> <p>Audio Inputs:            2x 6,35mm Jack Microphone</p> <p>Video Outputs:            1 x F-Bas Video            1 x S-Video            1 x Component Video (Y/PB/BR) (Progressive Scan)            1 x HDMI            1 x VGA</p> </div> </div>
<b>Series</b>	Pro	
<b>Description</b>	009	
<b>Type</b>	Karaoke Player	
<b>CD Format</b>	Yes	
<b>MP3 CD Format</b>	Yes	
<b>USB</b>	Yes, for Karaoke CD+G	
<b>Deckversion</b>	Singledeck	
<b>Cargocapacity</b>	Compact car	

Pioneer CDJ 2000 Nexus		
<b>Producer</b>	Pioneer	<div style="display: flex; align-items: center;">  <div style="flex-grow: 1;"> <p>100% Pitch +/- Function            CD, CD-R, CD-RW / DVD / DVD RW / MP3 / USB / Android / iPhone / SD-Cards / Mac &amp; Windows / AAC ProDJLink Compatibility</p> <p><b>50 €</b></p> <p>Could use Faderstartfunktion            MP3 Folder search            Scratchable            Large Display</p> </div> </div>
<b>Series</b>	CDJ	
<b>Description</b>	2000 Nexus	
<b>Type</b>	CD Player	
<b>CD Format</b>	Yes	
<b>MP3 CD Format</b>	Yes	
<b>USB</b>	Yes	
<b>Deckversion</b>	Singledeck	
<b>Cargocapacity</b>	Compact car	

<b>Pioneer CDJ 3000 Nexus</b>		
<b>Producer</b>	Pioneer	 
<b>Series</b>	CDJ	
<b>Description</b>	3000 Nexus	
<b>Type</b>	CD Player	
<b>CD Format</b>	Yes	
<b>MP3 CD Format</b>	Yes	
<b>USB</b>	Yes	
<b>Deckversion</b>	Singledeck	
<b>Cargocapacity</b>	Compact car	
		100% Pitch +/- Funktion MP3 / USB/ iPhone / SD-Cards / Mac & Windows / ALAC / AAC / AIFF / FLAC / WAV / FAT / FAT 32 / HFS+ / rekordbox / djay PRO AI for MAC / Traktor PRO 3 / ProDJ Link / Pro DJ Link Lighting / KUVU ready  Could use Faderstartfunktion MP3 Folder search Scratchable 9" HD-LCD-Touchscreen Display
		<b>70 €</b>

<b>Technics 1210 MK II</b>		
<b>Producer</b>	Technics	
<b>Series</b>	1210	
<b>Description</b>	MK II	
<b>Type</b>	Turntable	
<b>CD Format</b>	No	
<b>MP3 CD Format</b>	No	
<b>USB</b>	No	
<b>Deckversion</b>	Singledeck	
<b>Cargocapacity</b>	Compact car	
		Including Ortofon Concord System and Slip-Mat  QuarzmodeDirect-Drive Turntable
		<b>25 €</b>

## 1.6. Delay`s Controller

<b>The T. Racks DL 2/918</b>		
<b>Producer</b>	The T.Racks	
<b>Series</b>	DL	
<b>Description</b>	2/918	
<b>Limiter</b>	No (-)	
<b>Effects</b>	No (-)	
<b>Compressor</b>	No (-)	
<b>Equalizer</b>	No (-)	
<b>Gate / Expander</b>	No (-)	
<b>Cargocapacity</b>	Compact car	
		Digital 24bit stereo Delay Line Controller; Delay Time (max): 2x 2730 ms (=936,4 Meter) each channell - choosebale in Milliseconds, Meter or Feet; Noise Gate
		<b>10 €</b>

## 1.7. Mikrophones

Shure SM 58	
<b>Producer</b>	Shure
<b>Series</b>	SM
<b>Description</b>	58
<b>Type of usage</b>	Vocal
<b>Capsule</b>	Dynamic
<b>Characteristic</b>	Pocket
<b>Transfer</b>	Cable
<b>Phantompower</b>	No (-)
<b>Cargocapacity</b>	Bag



1 \* Microphone  
XLR Out  
High quality vocal microphone

**5 €**

Shure SM 57	
<b>Producer</b>	Shure
<b>Series</b>	SM
<b>Description</b>	57
<b>Type of usage</b>	Decline
<b>Capsule</b>	Dynamic
<b>Characteristic</b>	Pocket
<b>Transfer</b>	Cable
<b>Phantompower</b>	No (-)
<b>Cargocapacity</b>	Bag



1 \* Microphone  
XLR Out  
High quality vocal and instrumental microphone

Best usage for instrumental certification and as well for vocals

**5 €**

Shure Beta 58 A	
<b>Producer</b>	Shure
<b>Series</b>	Beta
<b>Description</b>	58 A
<b>Type of usage</b>	Vocal
<b>Capsule</b>	Dynamic
<b>Characteristic</b>	Superpocket
<b>Transfer</b>	Cable
<b>Phantompower</b>	No (-)
<b>Cargocapacity</b>	Bag



1 \* Microphone  
XLR Out  
High quality vocal microphone

**6 €**

Beyerdynamic Opus 67	
<b>Producer</b>	Beyerdynamic
<b>Series</b>	Opus
<b>Description</b>	67
<b>Type of usage</b>	Decline
<b>Capsule</b>	Dynamic
<b>Characteristic</b>	Hyperpocket
<b>Transfer</b>	Cable
<b>Phantompower</b>	No (-)
<b>Cargocapacity</b>	Bag



XLR Out  
For Drums (Toms and Snare) with flexible swan neck and special microphoneclamp MKV 87

**5 €**

<b>Sennheiser E 901 Interfacial microphone</b>	
<b>Producer</b>	Sennheiser
<b>Series</b>	E
<b>Description</b>	901
<b>Type of usage</b>	Decline
<b>Capsule</b>	Dynamic
<b>Characteristic</b>	Halfpocket
<b>Transfer</b>	Cable
<b>Phantompower</b>	Yes (needed)
<b>Cargocapacity</b>	Bag



XLR Out  
Frequency 20 Hz - 20 kHz  
For example for Bassdrum

Best usage for Bassdrum or grand piano certification, as well for Conferencing

**10 €**

<b>LD Systems BM1 Interfacial microphone</b>	
<b>Producer</b>	Sennheiser
<b>Series</b>	E
<b>Description</b>	901
<b>Type of usage</b>	Decline
<b>Capsule</b>	Dynamic
<b>Characteristic</b>	Halfpocket
<b>Transfer</b>	Cable
<b>Phantompower</b>	Yes (needed)
<b>Cargocapacity</b>	Bag



XLR Out

Best usage for Speech

**10 €**

<b>AKG D 112</b>	
<b>Producer</b>	AKG
<b>Series</b>	D
<b>Description</b>	112
<b>Type of usage</b>	Decline
<b>Capsule</b>	Dynamic
<b>Characteristic</b>	Pocket
<b>Transfer</b>	Cable
<b>Phantompower</b>	No (-)
<b>Cargocapacity</b>	Bag



XLR Out  
Frequency 20 Hz - 17 kHz  
Impedance 210 Ohm including clamp  
For example for Bassdrum, E-Bass, Tuba  
Dimensions: 150x70x115 mm  
Nettoweight: 320g

Best usage for Bassdrum certification

**5 €**

<b>Clockaudio C 600</b>	
<b>Producer</b>	Clockaudio
<b>Series</b>	C
<b>Description</b>	600
<b>Type of usage</b>	Decline
<b>Capsule</b>	Condensator
<b>Characteristic</b>	Pocket
<b>Transfer</b>	Cable
<b>Phantompower</b>	Yes (needed)
<b>Cargocapacity</b>	Bag



Frequency optimized for vocals and for instrumentals  
XLR Connection

Must be used with phantom power feeding.

Best usage for Overhead and atmosphere certification

**5 €**

<b>AKG C 1000 S MK III</b>	
<b>Producer</b>	AKG
<b>Series</b>	C
<b>Description</b>	1000 S MK III
<b>Type of usage</b>	Decline
<b>Capsule</b>	Condensator
<b>Characteristic</b>	Pocket
<b>Transfer</b>	Cable
<b>Phantompower</b>	Yes (needed)
<b>Cargocapacity</b>	Bag



Frequency optimized for vocals and for instrumentals, as well for chorus and orchestra  
Symmetric, with XLR-connectors

Could be used as well with a 9v block battery, that no phantom power feeding is needed.

Best usage for Overhead and atmosphere certification

**5 €**

<b>Clockaudio C33 E/SR</b>	
<b>Producer</b>	Clockaudio
<b>Series</b>	C
<b>Description</b>	33 E/SR
<b>Type of usage</b>	Conference
<b>Capsule</b>	Condensator
<b>Characteristic</b>	Pocket
<b>Transfer</b>	Cable
<b>Phantompower</b>	Yes (needed)
<b>Cargocapacity</b>	Bag



Elegant Condenser -Swan neck microphone with highsound loyalty, half fixed  
swan neck shaft, length 380mm,XLR-Output

**15 €**

<b>LD Systems D1015 CM</b>	
<b>Producer</b>	LD Systems
<b>Series</b>	D
<b>Description</b>	1015 CM
<b>Type of usage</b>	Conference
<b>Capsule</b>	Condensator
<b>Characteristic</b>	Pocket
<b>Transfer</b>	Cable
<b>Phantompower</b>	Yes (needed)
<b>Cargocapacity</b>	Bag



Elegant Condenser -Swan neck microphone with highsound loyalty, half fixed  
swan neck shaft, length 480mm,XLR-Output

**15 €**

<b>K&amp;M Additional rail 23550</b>	
<b>Producer</b>	K&M
<b>Series</b>	Additional rail
<b>Description</b>	23550
<b>Type of usage</b>	Adapter
<b>Capsule</b>	-
<b>Characteristic</b>	-
<b>Transfer</b>	-
<b>Phantompower</b>	-
<b>Cargocapacity</b>	Bag



This additional rail is able to be connected on every microphone stand and gives you the option, to use and connect 2 microphones instead of 1 microphone on one stand

**2 €**

<b>K&amp;M Tablecall station 29376</b>	
<b>Producer</b>	K&M
<b>Series</b>	Tablecall station
<b>Description</b>	29376
<b>Type of usage</b>	Adapter
<b>Capsule</b>	-
<b>Characteristic</b>	-
<b>Transfer</b>	-
<b>Phantompower</b>	-
<b>Cargocapacity</b>	Bag



K&M 29376 microphone-tablecallstation

**5 €**

<b>LD Systems WS 100 ML</b>	
<b>Producer</b>	LD Systems
<b>Series</b>	WS
<b>Description</b>	100 ML
<b>Type of usage</b>	Moderation
<b>Capsule</b>	-
<b>Characteristic</b>	Pocket
<b>Transfer</b>	By cable for wireless sender
<b>Phantompower</b>	Yes (5V)
<b>Cargocapacity</b>	Bag



Condenser microphone (Tiemicrophone)  
 Connector for LD Systems U508 BP Bodypack / Pocketsender plug  
 20 - 20.000 Hz  
 Color: black

ONLY for voice approval, to use with a LD Systems U508/518 BP Bodypack / Pocketsender (LD Systems U508/518 microphoneseries)

**5 €**

<b>LD Systems U508 HH Headset</b>	
<b>Producer</b>	LD Systems
<b>Series</b>	U500
<b>Description</b>	508 HH
<b>Type of usage</b>	Moderation
<b>Capsule</b>	-
<b>Characteristic</b>	Pocket
<b>Transfer</b>	By cable for wireless sender
<b>Phantompower</b>	Yes (5V)
<b>Cargocapacity</b>	Bag



Condenser microphone (Headsetmicrophone)  
 Connector for LD Systems U508 BP Bodypack / Pocketsender plug  
 70 - 16.000 Hz  
 125 dB SPL max.  
 Color: beige (skin-color)

ONLY for voice approval, to use with a LD Systems U508 BP Bodypack / Pocketsender (LD Systems U508 microphoneseries)

**5 €**

<b>LD Systems U508 BP Bodypack / Pocketsender</b>	
<b>Producer</b>	LD Systems
<b>Series</b>	U500
<b>Description</b>	508 BP
<b>Type of usage</b>	Pocket-sender
<b>Capsule</b>	-
<b>Characteristic</b>	-
<b>Transfer</b>	By microphone to receiver
<b>Phantompower</b>	Yes (5V)
<b>Cargocapacity</b>	Bag





Pocketsender / Bodypack Sender  
 Frequency 8: 823 - 832 MHz , 863 - 865 MHz  
 Display with Groups-, Channels- and Batterydisplay  
 On/Off-switch  
 Frequency transfer from the acceptor by Infrared  
 Plug for microphones (for example.: LD Systems U508 HH)

**5 €**

LD Systems U508 HHC / Condensator Handheld microphone		
<b>Producer</b>	LD Systems	
<b>Series</b>	U500	
<b>Description</b>	508 HHC	
<b>Type of usage</b>	Pocket-sender	
<b>Capsule</b>	-	
<b>Characteristic</b>	-	
<b>Transfer</b>	By microphone to receiver	
<b>Phantompower</b>	Yes (5V)	
<b>Cargocapacity</b>	Bag	
		Condensator Handheld microphone Frequency 8: 823 - 832 MHz , 863 - 865 MHz Display with Groups-, Channels- and Batterydisplay On/Off-switch Frequency transfer from the acceptor by Infrared  <b>10 €</b>

LD Systems U-Serie Instrumentenkabel		
<b>Producer</b>	LD Systems	
<b>Series</b>	U	
<b>Description</b>	Instrument-cable	
<b>Type of usage</b>	Decline	
<b>Capsule</b>	-	
<b>Characteristic</b>	-	
<b>Transfer</b>	By cable for wireless sender	
<b>Phantompower</b>	No (-)	
<b>Cargocapacity</b>	Bag	
		TGQ (3 Pol) to 6,35mm Jack mono for instrumental connection  TQG-Connector for LD Systems Bodypack connection  <b>5 €</b>  ONLY for instrumental connections, to use with a LD Systems Bodypack (LD Systems U- wireless microphone series)

LD Systems U508 Twin receiver / Twin acceptor		
<b>Producer</b>	LD Systems	
<b>Series</b>	U500	
<b>Description</b>	508 (DR)	
<b>Type of usage</b>	Wireless acceptor	
<b>Capsule</b>	-	
<b>Characteristic</b>	-	
<b>Transfer</b>	With cable to mixer	
<b>Phantompower</b>	No (-)	
<b>Cargocapacity</b>	Compact car	
		Acceptor Frequency 8: 823 - 832 MHz , 863 - 865 MHz Frequency transfer from the acceptor to the sender by Infrared 3x XLR-Output (each microphone single and 1x sum mix) 2x BNC Antennas  <b>40 €</b>  ONLY able to use for the reception from LD Systems U508 Bodypack Pocketsender or LD Systems U508 Handheldmicrophonesender (LD Systems U508 wireless microphoneseries)

LD Systems U508 Single receiver / Single acceptor			
<b>Producer</b>	LD Systems		
<b>Series</b>	U500		
<b>Description</b>	508 (DR)		
<b>Type of usage</b>	Wireless acceptor		
<b>Capsule</b>	-		
<b>Characteristic</b>	-		
<b>Transfer</b>	With cable to mixer		
<b>Phantompower</b>	No (-)		
<b>Cargocapacity</b>	Compact car		
		Acceptor Frequency 8: 823 - 832 MHz , 863 - 865 MHz Frequency transfer from the acceptor to the sender by Infrared 1x XLR-Output 2x BNC Antennas  ONLY able to use for the reception from LD Systems U508 Bodypack Pocketsender or LD Systems U508 Handheldmicrophonesender (LD Systems U508 wireless microphoneseries)	<b>20 €</b>

LD Systems U518 HH Headset			
<b>Producer</b>	LD Systems		
<b>Series</b>	U500		
<b>Description</b>	518 HH		
<b>Type of usage</b>	Moderation		
<b>Capsule</b>	-		
<b>Characteristic</b>	Pocket		
<b>Transfer</b>	By cable for wireless sender		
<b>Phantompower</b>	Yes (5V)		
<b>Cargocapacity</b>	Bag		
		Condenser microphone (Headsetmicrophone) Connector for LD Systems U518 BP Bodypack / Pocketsender plug 70 - 16.000 Hz 125 dB SPL max. Color: beige (skin-color)	<b>5 €</b>
		ONLY for voice approval, to use with a LD Systems U518 BP Bodypack / Pocketsender (LD Systems U518 microphoneseries)	

LD Systems U518 BP Bodypack / Pocketsender			
<b>Producer</b>	LD Systems		
<b>Series</b>	U500		
<b>Description</b>	518 BP		
<b>Type of usage</b>	Pocket-sender		
<b>Capsule</b>	-		
<b>Characteristic</b>	-		
<b>Transfer</b>	By microphone to receiver		
<b>Phantompower</b>	Yes (5V)		
<b>Cargocapacity</b>	Bag		
		Pocketsender / Bodypack Sender Frequency: 1785 - 1800 MHz Display with Groups-, Channels- and Batterydisplay On/Off-switch Frequency transfer from the acceptor by Infrared Plug for microphones (for example.: LD Systems U518 HH)	<b>5 €</b>

LD Systems U518 HHC / Condensator Handheld microphone	
<b>Producer</b>	LD Systems
<b>Series</b>	U500
<b>Description</b>	518 HHC
<b>Type of usage</b>	Pocket-sender
<b>Capsule</b>	-
<b>Characteristic</b>	-
<b>Transfer</b>	By microphone to receiver
<b>Phantompower</b>	Yes (5V)
<b>Cargocapacity</b>	Bag



Condensator Handheld microphone  
 Frequency: 1785 - 1800 MHz  
 Display with Groups-, Channels- and Batterydisplay  
 On/Off-switch  
 Frequency transfer from the acceptor by Infrared

**10 €**

LD Systems U-Serie Instrumentenkabel	
<b>Producer</b>	LD Systems
<b>Series</b>	U
<b>Description</b>	Dynamic changeable head
<b>Type of usage</b>	Decline
<b>Capsule</b>	-
<b>Characteristic</b>	-
<b>Transfer</b>	Chanable for wireless sender
<b>Phantompower</b>	No (-)
<b>Cargocapacity</b>	Bag



Changeable head for condenser mic, changes to dynmic handheld wireless microphone

**5 €**

ONLY for LD U- wireless microphone series

LD Systems U518 Twin receiver / Twin acceptor	
<b>Producer</b>	LD Systems
<b>Series</b>	U500
<b>Description</b>	518 (DR)
<b>Type of usage</b>	Wireless acceptor
<b>Capsule</b>	-
<b>Characteristic</b>	-
<b>Transfer</b>	With cable to mixer
<b>Phantompower</b>	No (-)
<b>Cargocapacity</b>	Compact car



Acceptor  
 Frequency: 1785 - 1800 MHz  
 Frequency transfer from the acceptor to the sender by Infrared  
 3x XLR-Output (each microphone single and 1x sum mix)  
 2x BNC Antennas

**40 €**

ONLY able to use for the reception from LD Systems U518 Bodypack Pocketsender  
 or  
 LD Systems U518 Handheldmicrophonesender (LD Systems U518 wireless microphoneseries)

LD Systems U518 Single receiver / Single acceptor		
<b>Producer</b>	LD Systems	<div style="display: flex; align-items: center; justify-content: center;">  <div style="margin-left: 20px;"> <p>Acceptor            Frequency: 1785 - 1800 MHz            Frequency transfer from the acceptor to the sender by Infrared            1x XLR-Output            2x BNC Antennas</p> <p>ONLY able to use for the reception from LD Systems U518 Bodypack Pocketsender            or            LD Systems U518 Handheldmicrophonesender (LD Systems U518 wireless microphoneseries)</p> </div> </div>
<b>Series</b>	U500	
<b>Description</b>	518 (DR)	
<b>Type of usage</b>	Wireless acceptor	
<b>Capsule</b>	-	
<b>Characteristic</b>	-	
<b>Transfer</b>	With cable to mixer	
<b>Phantompower</b>	No (-)	
<b>Cargocapacity</b>	Compact car	

## 1.8. Add On`s (Stands, DI Boxes, Line-Isolators, analog & digital Multicores, Stageboxes, Audiocables and -adapter, wireless signal broadcast)

Loudspeakerstand		
<b>Producer</b>	-	
<b>Series</b>	-	
<b>Description</b>	-	
<b>Type</b>	Stand	
<b>Type of usage</b>	Loudspeaker	
<b>Cargocapacity</b>	Compact car	
		Made of aluminium GS proved till 35KG central load Variable of highs between 1,3m – 2m <span style="float: right;"><b>2 €</b></span>

K&M 214/6 Loudspeakerstand		
<b>Producer</b>	K&M	
<b>Series</b>	Loudspeaker-stand	
<b>Description</b>	214/6	
<b>Type</b>	Stand	
<b>Type of usage</b>	Loudspeaker	
<b>Cargocapacity</b>	Compact car	
		Made of aluminium GS proved till 50KG central load Variable of highs between 1,3m – 2,1m <span style="float: right;"><b>3 €</b></span>

K&M 21463 Loudspeakerstand with Gasspring system		
<b>Producer</b>	K&M	
<b>Series</b>	Loudspeaker-stand	
<b>Description</b>	21463	
<b>Type</b>	Stand	
<b>Type of usage</b>	Loudspeaker	
<b>Cargocapacity</b>	Compact car	
		Made of aluminium GS proved till 50KG central load Variable of highs between 1,3m – 2,1m Helps to lift up till 25 Kg with a Gasspring <span style="float: right;"><b>5 €</b></span>

K&M 21302 Loudspeakerstand		
<b>Producer</b>	K&M	
<b>Series</b>	Loudspeaker-stand	
<b>Description</b>	21302	
<b>Type</b>	Stand	
<b>Type of usage</b>	Loudspeaker	
<b>Cargocapacity</b>	Compact car	
		Made of aluminium GS proved till 30KG central load Variable of highs between 1,3m – 2,1m With crank <span style="float: right;"><b>5 €</b></span>

K&M 21357 Distance pole with Gasspring system		
<b>Producer</b>	K&M	
<b>Series</b>	Loudspeaker-distance pole	
<b>Description</b>	21356	
<b>Type</b>	distance pole	
<b>Type of usage</b>	Loudspeaker	
<b>Cargocapacity</b>	Compact car	
		Made of aluminium with M20 winding GS proved till 50KG central load Variable of highs Helps to lift up till 17 Kg with a Gasspring For mounting of a Top system on a Subwoofer <span style="float: right;"><b>3,50 €</b></span>

<b>K&amp;M 21340 Distance pole with crank</b>	
<b>Producer</b>	K&M
<b>Series</b>	Loudspeaker-distance pole
<b>Description</b>	21340
<b>Type</b>	distance pole
<b>Type of usage</b>	Loudspeaker
<b>Cargocapacity</b>	Compact car
	
<p>Made of aluminium with M20 winding GS proved till 50KG central load Variable of hights With crank For mounting of a Top system on a Subwoofer</p>	
<b>3 €</b>	

<b>Gravity Multifunctionalstand LS 331 B</b>	
<b>Producer</b>	Gravity
<b>Series</b>	-
<b>Description</b>	LS 331 B
<b>Type</b>	Stativ
<b>Type of usage</b>	Multifunctional
<b>Cargocapacity</b>	2x Tasche
	
<p>Gravity Multifunctionalstand LS 331 B made of steel GS proofed up to 20Kg centric load 35mm Standard pipe Height adjustable between 1,42m – 2,42m Weight incl. baseplate (50 cm x 50 cm): 17,8kg Incl. 3x cableclamp</p>	
<b>6 €</b>	

<b>Cableclamp for loudspeakerstands</b>	
<b>Producer</b>	Gravity
<b>Series</b>	-
<b>Description</b>	GSACC35B
<b>Type</b>	Cableclamp
<b>Type of usage</b>	Stands
<b>Cargocapacity</b>	Bag
	
<p>Gravity GSACC35B cableclamp for 35mm - 36mm pipes, f.e. for loudspeakerstands to hide cables the correct way from top to bottom, black</p>	
<b>1 €</b>	

<b>Adapterbolt</b>	
<b>Producer</b>	-
<b>Series</b>	-
<b>Description</b>	-
<b>Type</b>	Adapter
<b>Type of usage</b>	Loudspeaker
<b>Cargocapacity</b>	Compact car
	
<p>Adapterbolt M20/loud speaker muff</p>	
<b>2 €</b>	

<b>K&amp;M 26250 Mikrophone stand round foot</b>	
<b>Producer</b>	K&M
<b>Series</b>	Mikrophone-stand
<b>Description</b>	26250
<b>Type</b>	Mikrophone-stand
<b>Type of usage</b>	Mikrophone
<b>Cargocapacity</b>	Compact car
	
<p>Variable of hights With round foot Could be used with single hand</p>	
<b>5 €</b>	

Mikrophone stand		
<b>Producer</b>	-	
<b>Series</b>	-	
<b>Description</b>	-	
<b>Type</b>	Mikrophone-stand	
<b>Type of usage</b>	Mikrophone	
<b>Cargocapacity</b>	Compact car	
		Variable of hights with additional music rack <b>3 €</b>

Mikrophone stand (small)		
<b>Producer</b>	-	
<b>Series</b>	-	
<b>Description</b>	-	
<b>Type</b>	Mikrophone stand	
<b>Type of usage</b>	Mikrophone	
<b>Cargocapacity</b>	Compact car	
		Microphone stand, for example bassdrum microphone`s <b>3 €</b>

K&M 23750 Mikrofon-Angel		
<b>Producer</b>	K&M	
<b>Series</b>	-	
<b>Description</b>	23750	
<b>Type</b>	Mikrofon-angle	
<b>Type of usage</b>	Mikrophone	
<b>Cargocapacity</b>	Compact car	
		Mikrofon angle for external Camcorder microphones Weight 0,3 kg Adjustable from 635 up to 1600 mm <b>5 €</b>

K&M 232 BK Tablemikrophone stand		
<b>Producer</b>	K&M	
<b>Series</b>	232	
<b>Description</b>	BK	
<b>Type</b>	Mikrophone stand	
<b>Type of usage</b>	Mikrophone	
<b>Cargocapacity</b>	Compact car	
		including small tube 175mm high including socket <b>3 €</b>

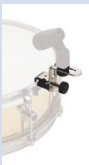
K&M 24030 Microphone holder for Drums		
<b>Producer</b>	K&M	
<b>Series</b>	24030	
<b>Description</b>	-	
<b>Type</b>	Mikrophone - holder	
<b>Type of usage</b>	Mikrophone	
<b>Cargocapacity</b>	Compact car	
		Microphone holder for drums in black <b>2 €</b>

Palmer Line Isolator PLI-03		
<b>Producer</b>	Palmer	
<b>Series</b>	Isolator	
<b>Description</b>	PLI-03	
<b>Type</b>	Isolator	
<b>Type of usage</b>	Filter	
<b>Cargocapacity</b>	Compact car	
		Chinch IN/OUT Stereo Trafosym. 1:1 +6dB 2 channel <b>5 €</b>

<b>Palmer Line Isolator PLI-02</b>		
<b>Producer</b>	Palmer	 XLR / 6,35mm Jack IN XLR OUT Stereo Trafosym. 1:1 +20 dB 2 channel
<b>Series</b>	Isolator	
<b>Description</b>	PLI-02	
<b>Type</b>	Isolator	
<b>Type of usage</b>	Filter	
<b>Cargocapacity</b>	Compact car	
		<b>5 €</b>

<b>Palmer PAN-01 DI-Box</b>		
<b>Producer</b>	Palmer	 Passive DI-Box Jack IN XLR / Jack OUT
<b>Series</b>	DI-Box	
<b>Description</b>	PAN-01	
<b>Type</b>	Isolator	
<b>Type of usage</b>	Filter	
<b>Cargocapacity</b>	Compact car	
		<b>3 €</b>

<b>Digital Multicore Cabledrum 50m</b>		
<b>Producer</b>	-	 Neutrik RJ45 connectors  Length 50 Meter
<b>Series</b>	-	
<b>Description</b>	-	
<b>Type</b>	Network digital multicore	
<b>Type of usage</b>	Supported Mixers and stageboxes	
<b>Cargocapacity</b>	Compact car	
		<b>40 €</b>

<b>Digital Multicore Cabledrum 75m</b>		
<b>Producer</b>	-	 Neutrik RJ45 connectors  Length 75 Meter
<b>Series</b>	-	
<b>Description</b>	-	
<b>Type</b>	Network digital multicore	
<b>Type of usage</b>	Supported Mixers and stageboxes	
<b>Cargocapacity</b>	Compact car	
		<b>50 €</b>

<b>Behringer S16 - Digital Stagebox</b>		
<b>Producer</b>	Behringer	 Digital Stagebox for Behringer X32 Compact Digitalmixer, to use with digital multicore
<b>Series</b>	S16	
<b>Description</b>	-	
<b>Type</b>	Digital Stagebox	
<b>Type of usage</b>	-	
<b>Cargocapacity</b>	Compact car	
		<b>30 €</b>

<b>Behringer S32 - Digital Stagebox</b>		
<b>Producer</b>	Behringer	 Digital Stagebox for Behringer X32 Digitalmixer, to use with digital multicore <span style="float: right;"><b>50 €</b></span>
<b>Series</b>	S32	
<b>Description</b>	-	
<b>Type</b>	Digital Stagebox	
<b>Type of usage</b>	-	
<b>Cargocapacity</b>	Compact car	

<b>Multicore 8-line</b>		
<b>Producer</b>	-	 Multicore XLR 15m 8 - line <span style="float: right;"><b>5 €</b></span>
<b>Series</b>	-	
<b>Description</b>	-	
<b>Type</b>	Multicore	
<b>Type of usage</b>	Stage	
<b>Cargocapacity</b>	Compact car	

<b>Audiocable 3,5mm Jack</b>		
<b>Producer</b>	-	 3,5mm Jackto 3,5mm Jack Lenght 1 Meter <span style="float: right;"><b>1 €</b></span>
<b>Series</b>	-	
<b>Description</b>	-	
<b>Type</b>	Audiocable	
<b>Type of usage</b>	DJ	
<b>Cargocapacity</b>	Bag	

<b>Audiocable 6,35mm Jack</b>		
<b>Producer</b>	-	 6,35mm Jackto 6,35mm Jack Lenght0,60 Meter / 3 Meter / 5 Meter <span style="float: right;"><b>1 €</b></span>
<b>Series</b>	-	
<b>Description</b>	-	
<b>Type</b>	Audiocable	
<b>Type of usage</b>	Stage	
<b>Cargocapacity</b>	Bag	

<b>Audiocable Cinch</b>		
<b>Producer</b>	-	 Cinch to Cinch cable Lenght 3 Meter <span style="float: right;"><b>1€</b></span>
<b>Series</b>	-	
<b>Description</b>	-	
<b>Type</b>	Audiocable	
<b>Type of usage</b>	DJ	
<b>Cargocapacity</b>	Bag	

<b>Audiocable Speakon</b>		
<b>Producer</b>	Neutrik	 Speakon to Speakon Kab cable Lenght 1 / 5 / 10 / 15 Meter <span style="float: right;"><b>2-5 €</b></span>
<b>Series</b>	-	
<b>Description</b>	-	
<b>Type</b>	Audiocable	
<b>Type of usage</b>	Loudspeaker	
<b>Cargocapacity</b>	Bag	

Audiocable XLR		
<b>Producer</b>	Neutrik	XLR (m) to XLR (f)
<b>Series</b>	-	
<b>Description</b>	-	
<b>Type</b>	Audiocable	
<b>Type of usage</b>	Loudspeaker, Stage	
<b>Cargocapacity</b>	Bag	
		Length 10 Meter (3 Pol)
		<b>1 €</b>

Audiocable XLR		
<b>Producer</b>	Neutrik	XLR (m) to XLR (f)
<b>Series</b>	-	
<b>Description</b>	-	
<b>Type</b>	Audiocable	
<b>Type of usage</b>	Loudspeaker, Stage	
<b>Cargocapacity</b>	Bag	
		Length 1 / 3 Meter (3 Pol)
		<b>0,50 – 1 €</b>

Audiocable XLR Cabledrum		
<b>Producer</b>	-	XLR (m) to XLR (m or f on the cabledrum)
<b>Series</b>	-	
<b>Description</b>	-	
<b>Type</b>	Audiocable	
<b>Type of usage</b>	Loudspeaker, Stage	
<b>Cargocapacity</b>	Compact car	
		Length 30 Meter (3 Pol)
		<b>5 €</b>

Audiocable Insert		
<b>Producer</b>	-	Length 3 Meter, 6,35mm Jack Stereo to 2x 6,35mm Jack Mono
<b>Series</b>	-	
<b>Description</b>	-	
<b>Type</b>	Audiocable	
<b>Type of usage</b>	FOH	
<b>Cargocapacity</b>	Bag	
		<b>1 €</b>

Audiocable XLR to Cinch		
<b>Producer</b>	Neutrik	XLR (m) to Cinch
<b>Series</b>	-	
<b>Description</b>	-	
<b>Type</b>	Audiocable Adapter	
<b>Type of usage</b>	DJ, FOH	
<b>Cargocapacity</b>	Bag	
		Length 3 Meter (3 Pol)
		<b>2 €</b>

Audiocable XLR to 6,35mm Jack		
<b>Producer</b>	Neutrik	XLR (f) to 6,35mm Jack
<b>Series</b>	-	
<b>Description</b>	-	
<b>Type</b>	Audiocable Adapter	
<b>Type of usage</b>	DJ, FOH	
<b>Cargocapacity</b>	Bag	
		Length 5 Meter (3 Pol)
		<b>1 €</b>

Audiocable XLR to 6,35mm Jack Stereo		
<b>Producer</b>	Neutrik	
<b>Series</b>	-	
<b>Description</b>	-	
<b>Type</b>	Audiocable Adapter	
<b>Type of usage</b>	DJ, FOH	
<b>Cargocapacity</b>	Bag	XLR (m) to 6,35mm Stereo Jack  Length 5 Meter (3 Pol) - (symetrisch)  <b>1 €</b>

Audiocable Cinch to 6,35mm Jack Mono		
<b>Producer</b>	-	
<b>Series</b>	-	
<b>Description</b>	-	
<b>Type</b>	Audiocable Adapter	
<b>Type of usage</b>	DJ, FOH	
<b>Cargocapacity</b>	Bag	Cinch to 6,35mm Mono Jack  Length 3 Meter  <b>1 €</b>

Audiocable Cinch to 6,35mm Jack Stereo		
<b>Producer</b>	-	
<b>Series</b>	-	
<b>Description</b>	-	
<b>Type</b>	Audiocable Adapter	
<b>Type of usage</b>	DJ, FOH	
<b>Cargocapacity</b>	Bag	Cinch to 6,35mm Stereo Jack  Länge 3 Meter  <b>1 €</b>

Audiocable 6,35mm Klinke Stereo		
<b>Producer</b>	-	
<b>Series</b>	-	
<b>Description</b>	-	
<b>Type</b>	Audiocable Adapter	
<b>Type of usage</b>	Keyboards	
<b>Cargocapacity</b>	Bag	6,35mm Stereo Jackto 6,35mm Stereo Jack  Lenght 3 Meter  <b>1 €</b>

Audioadapter 3,5mm Jack to Cinch		
<b>Producer</b>	-	
<b>Series</b>	-	
<b>Description</b>	-	
<b>Type</b>	Audio-adapter	
<b>Type of usage</b>	DJ, FOH	
<b>Cargocapacity</b>	Bag	Audioadapter 3,5mm Jack to Cinch or Audiocable 3,5mm Jack to Cinch  <b>2 €</b>

Audioadapter Cinch auf 6,35mm Klinke		
<b>Producer</b>	-	
<b>Series</b>	-	
<b>Description</b>	-	
<b>Type</b>	Audio-adapter	
<b>Type of usage</b>	DJ, FOH	
<b>Cargocapacity</b>	Bag	Audioadapter Cinch to 6,35mm Jack  <b>1 €</b>

Audioadapter Speakon Connector	
<b>Producer</b>	Neutrik
<b>Series</b>	-
<b>Description</b>	-
<b>Type</b>	Audio-adapter
<b>Type of usage</b>	DJ, FOH
<b>Cargocapacity</b>	Bag



For the connection between 2 SpeakOn cable`s

**1 €**

Audioadapter Cinch Connector	
<b>Producer</b>	-
<b>Series</b>	-
<b>Description</b>	-
<b>Type</b>	Audio-adapter
<b>Type of usage</b>	DJ, FOH
<b>Cargocapacity</b>	Bag



For the connection between 2 Cinch cable`s

**1 €**

Audiocable Speakon to 6,35mm Jack	
<b>Producer</b>	Neutrik
<b>Series</b>	-
<b>Description</b>	-
<b>Type</b>	Audiocable
<b>Type of usage</b>	Loudspeaker
<b>Cargocapacity</b>	Bag



For the possibility to connect loud speakers with Jack-In`s with normal SpeakOn-cable

**1 €**

Audiocable XLR Y-Adapter	
<b>Producer</b>	Neutrik
<b>Series</b>	-
<b>Description</b>	-
<b>Type</b>	Audiocable
<b>Type of usage</b>	DJ, FOH, Stage
<b>Cargocapacity</b>	Bag

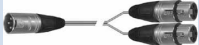

Splitt to 2 Signal resources

**1 €**

Audiocable Cinch Y-Adapter	
<b>Producer</b>	-
<b>Series</b>	-
<b>Description</b>	-
<b>Type</b>	Audiocable
<b>Type of usage</b>	DJ, FOH
<b>Cargocapacity</b>	Bag



Splitt auf 2 Signalquellen

**1 €**

Audioadapter 6,35mm Jack (f) to Cinch	
<b>Producer</b>	-
<b>Series</b>	-
<b>Description</b>	-
<b>Type</b>	Audio-adapter
<b>Type of usage</b>	DJ, FOH
<b>Cargocapacity</b>	Bag



6,35mm Jack (female) to Cinch

**1 €**

<b>Audioadapter XLR (f) to 6,35mm Jack (m)</b>	
<b>Producer</b>	Neutrik
<b>Series</b>	-
<b>Description</b>	-
<b>Type</b>	Audio-adapter
<b>Type of usage</b>	DJ, FOH, Stage
<b>Cargocapacity</b>	Bag



XLR (female) to 6,35mm Jack (male)

**1 €**

<b>Audioadapter XLR (m) to 6,35mm Jack (m)</b>	
<b>Producer</b>	Neutrik
<b>Series</b>	-
<b>Description</b>	-
<b>Type</b>	Audio-adapter
<b>Type of usage</b>	DJ, FOH, Stage
<b>Cargocapacity</b>	Bag



XLR (male) to 6,35mm Jack (male)

**1 €**

<b>Audioadapter 3,5mm Jack (f) to 6,35mm Jack (m)</b>	
<b>Producer</b>	Neutrik
<b>Series</b>	-
<b>Description</b>	-
<b>Type</b>	Audio-adapter
<b>Type of usage</b>	DJ, FOH, Stage
<b>Cargocapacity</b>	Bag



3,5mm Jack (female) to 6,35mm Jack (male)

**1 €**

<b>Audioadapter 6,35mm Jack (f) to 3,5mm Jack (m)</b>	
<b>Producer</b>	Neutrik
<b>Series</b>	-
<b>Description</b>	-
<b>Type</b>	Audio-adapter
<b>Type of usage</b>	DJ, FOH, Stage
<b>Cargocapacity</b>	Bag



6,35mm Jack (female) to 3,5mm Jack (male)

**1 €**

<b>Audioadapter XLR (m) to XLR (m)</b>	
<b>Producer</b>	Neutrik
<b>Series</b>	-
<b>Description</b>	-
<b>Type</b>	Audio-adapter
<b>Type of usage</b>	DJ, FOH, Stage
<b>Cargocapacity</b>	Bag



Adapter XLR (m) to XLR (m)

**1 €**

<b>Audioadapter XLR (f) auf XLR (f)</b>	
<b>Producer</b>	Neutrik
<b>Series</b>	-
<b>Description</b>	-
<b>Type</b>	Audio-adapter
<b>Type of usage</b>	DJ, FOH, Stage
<b>Cargocapacity</b>	Bag



Adapter XLR (f) to XLR (f)

**1 €**

<b>Audioadapter XLR 4-line Multicore to Kabeltrommel</b>	
<b>Producer</b>	-
<b>Series</b>	-
<b>Description</b>	-
<b>Type</b>	Audio-adapter
<b>Type of usage</b>	FOH, Stage
<b>Cargocapacity</b>	Compact car



XLR 3 Pol 4-line Multicore on cabledrum with 25 Metern lenght

Male (cabledrum) to Female (cable)

**5 €**

<b>Audioadapter Cinch (f)to XLR (m)</b>	
<b>Producer</b>	Neutrik
<b>Series</b>	-
<b>Description</b>	-
<b>Type</b>	Audio-adapter
<b>Type of usage</b>	DJ, FOH, Stage
<b>Cargocapacity</b>	Bag



Adapter Cinch (f) to XLR (m)

**1 €**

<b>Standwarning stripes</b>	
<b>Producer</b>	-
<b>Series</b>	-
<b>Description</b>	-
<b>Type</b>	Savety
<b>Type of usage</b>	Audience floor
<b>Cargocapacity</b>	Bag



Warning Stripe for audio- & lightequipment base of stands with hook-and-loop fastener for easy mounting, for build ups in the near from the audience

**1 €**

<b>XLR (female) to 3,5mm Jack adaptercable with 3m lenght</b>	
<b>Producer</b>	-
<b>Series</b>	-
<b>Description</b>	-
<b>Type</b>	Audio-adaptercable
<b>Type of usage</b>	-
<b>Cargocapacity</b>	Bag



XLR (female) to 3,5mm Jack (male) adaptercable with 3m lenght

f.e. to connect external microphones with camcorders or cameras

**1 €**

## 1.9. Audio Sets

Set 01 – RCF Evox JMix8 with wireless microphone	
<b>Producer</b>	RCF
<b>Series</b>	Evox
<b>Description</b>	JMix8
<b>Type</b>	Fullrange
<b>Musictype</b>	
<b>Listener(Pax)</b>	Max. 80
<b>RMS Power</b>	700
<b>Build up manual</b>	No (-)
<b>Cargocapacity</b>	Compact car



- ✓ RCF Evox JMix8 Activesystem incl. distance row and Transportrolley with integrated Mixer and Smartphone connection cable
- ✓ Wireless microphone

**94 €**



Set 02 - LD Systems Stinger 02.1 Set	
<b>Producer</b>	LD Systems
<b>Series</b>	Stinger G3 A
<b>Description</b>	Stinger 02.1
<b>Type</b>	Fullrange
<b>Musictype</b>	Charts
<b>Listener (Pax)</b>	Max. 150
<b>RMS Power</b>	1050
<b>Build up manual</b>	Yes (📖)
<b>Cargocapacity</b>	Compact car



- ✓ LD Systems Stinger G3 A Activesystem incl. Stands
- ✓ Behringer DX 626 Club Mixer with 3 Stereochannels and one Mikrophonechannel
- ✓ Cablemicrophone
- ✓ Numark ear-phone
- ✓ Notebook connection set (also useable for Smartphones with earphones output)

**75 €**



Set 03 – LD Systems IEM 306 Set	
<b>Producer</b>	LD Systems
<b>Series</b>	IEM
<b>Description</b>	306
<b>Type</b>	In Ear Monitoring
<b>Musictype</b>	-
<b>Listener (Pax)</b>	-
<b>RMS Power</b>	-
<b>Build up manual</b>	No (📖)
<b>Cargocapacity</b>	Compact car



- ✓ LD Systems IEM 306 Singlesender
- ✓ LD Systems IEM 306 Bodypackreceiver
- ✓ LD Systems IEM 306 Earplugs in black
- ✓ XLR cable
- ✓ Batteries

**30 €**

Set 04 - Drumkitdecline Set	
<b>Producer</b>	Various
<b>Series</b>	-
<b>Description</b>	-
<b>Type</b>	Drumkit decline
<b>Musictype</b>	Live
<b>Listener (Pax)</b>	-
<b>RMS Power</b>	-
<b>Build up manual</b>	No (-)
<b>Cargocapacity</b>	Compact car



- ✓ 4x Shure SM 57
- ✓ 1x Beyerdynamic Opus 67
- ✓ 2x Clockaudio C600
- ✓ 1x AKG D112
- ✓ 3x Drumclamp K&M 24030
- ✓ 3x Mikrophonestand
- ✓ 1x Mikrophonestand small
- ✓ 1x Multicore 8line XLR to XLR
- ✓ 7x XLR to XLR Patch 3 Meter

**40 €**

Set 08 - Karaoke Set	
<b>Producer</b>	Various
<b>Series</b>	-
<b>Description</b>	-
<b>Type</b>	Karaoke Set
<b>Musictype</b>	Karaoke
<b>Listener (Pax)</b>	-
<b>RMS Power</b>	-
<b>Build up manual</b>	No (-)
<b>Cargocapacity</b>	Compact car



- ✓ 1x Sunfly Pro-009 / Madboy MFP-1500 Karaoke Player
- ✓ 1x Speaker for 50 Persons
- ✓ 1x K&M Loudspeakerstand
- ✓ 2x Shure SM 58 cablemicrophone
- ✓ 1x 24" Monitor including cables to connect it to the Karaoke Player
- ✓ cables to connect everything to the microphones, the loudspeaker and to the Karaoke Player
- ✓ Inclusive nearly 900 german and english Karaoke Songs

**90 €**

Set 09 - LD Systems U508 BPHH 2	
<b>Producer</b>	LD Systems
<b>Series</b>	U500
<b>Description</b>	U508 BPHH 2
<b>Type</b>	2x Wireless Headset
<b>Musictype</b>	Live
<b>Listener (Pax)</b>	-
<b>RMS Power</b>	-
<b>Build up manual</b>	No (-)
<b>Cargocapacity</b>	Compact car



- ✓ 2x LD Systems U508 HH Headset microphone in color skin
- ✓ 2x LD Systems U508 BP pocketsender / bodypack with Frequency 8
- ✓ 1x LD Systems U508 DR Twin acceptor with Frequency 8
- ✓ 2x XLR to XLR Patch 3 Meter
- ✓ **Also available in frequencies 1785-1800 MHz as Set no. 09\_1**

**60 €**

Set 10 - LD Systems U508 HHC 2	
<b>Producer</b>	LD Systems
<b>Series</b>	U500
<b>Description</b>	U508 HHC 2
<b>Type</b>	2x Wireless Handheld microphone
<b>Musictype</b>	Live
<b>Listener (Pax)</b>	-
<b>RMS Power</b>	-
<b>Build up manual</b>	No (-)
<b>Cargocapacity</b>	Compact car



- ✓ 2x LD Systems U508 HHC Condensator Handheld microphone with Frequency 8
- ✓ 1x LD Systems U508 DR Twin acceptor with Frequency 8
- ✓ 2x XLR to XLR Patch 3 Meter
- ✓ **Also available in frequencies 1785-1800 MHz as Set no. 10\_1**

**60 €**



Set 11 - LD Systems U508 BPHH				
<b>Producer</b>	LD Systems		✓ LD Systems U508 HH Headset microphone in color skin	<b>30 €</b>
<b>Series</b>	U500		✓ LD Systems U508 BP pocketsender / bodypack with Frequency 8	
<b>Description</b>	U508 BPHH		✓ LD Systems U508 DS Single acceptor with Frequency 8	
<b>Type</b>	Wireless Headset		✓ XLR to XLR Patch 3 Meter	
<b>Musictype</b>	Live		✓ <b>Also available in frequencys 1785-1800 MHz as Set no. 11_1</b>	
<b>Listener (Pax)</b>	-			
<b>RMS Power</b>	-			
<b>Build up manual</b>	No (-)			
<b>Cargocapacity</b>	Compact car			

Set 12 - LD Systems U508 HHC				
<b>Producer</b>	LD Systems		✓ LD Systems U508 HHC Condensator Handheld microphone with Frequency 8	<b>30 €</b>
<b>Series</b>	U500		✓ LD Systems U508 DS Single acceptor with Frequency 8	
<b>Description</b>	U508 HHC		✓ XLR to XLR Patch 3 Meter	
<b>Type</b>	Wireless Handheld microphone		✓ <b>Also available in frequencys 1785-1800 MHz as Set no. 12_1</b>	
<b>Musictype</b>	Live			
<b>Listener (Pax)</b>	-			
<b>RMS Power</b>	-			
<b>Build up manual</b>	No (-)			
<b>Cargocapacity</b>	Compact car			

Set 13 - LD Systems U508 Directional antenna Set				
<b>Producer</b>	LD Systems		✓ 2x LD Systems WS 100 DA Omnidirectional antenna	<b>50 €</b>
<b>Series</b>	U500		✓ 2x LD Systems U508 WS 100 AB Antennaamplifier	
<b>Description</b>	-		✓ 2x TNC cable 0,5m	
<b>Type</b>	Wireless microphone Directional antenna		✓ 2x TNC cable 10m	
<b>Musictype</b>	Live		✓ 2x Superclamp with Adapter	
<b>Listener (Pax)</b>	-		✓ 2x Mikrofonstand	
<b>RMS Power</b>	-		✓ LD Systems WIN 42 AD Antennasplitter	
<b>Build up manual</b>	No (-)			
<b>Cargocapacity</b>	Compact car			

Set 14 – Behringer X32 with S32 Stagebox Set				
<b>Producer</b>	Behringer		✓ 1x Behringer X32 Digitalmixer	<b>130 €</b>
<b>Series</b>	X32 / S32		✓ 1x Behringer S32 Digital Stagebox	
<b>Description</b>	-		✓ 1x Digital Multicore 50m	
<b>Type</b>	FOH Mixer		✓ 1x Digital Multicore 75m	
<b>Musictype</b>	Live / FOH		✓ 1x WIFI Router	
<b>Listener (Pax)</b>	-		✓ 1x Tablet with X32 App	
<b>RMS Power</b>	-			
<b>Build up manual</b>	No (-)			
<b>Cargocapacity</b>	Station wagon			

Set 15 – Behringer X32 Compact with S16 Stagebox Set	
<b>Producer</b>	Behringer
<b>Series</b>	X32 Compact / S16
<b>Description</b>	-
<b>Type</b>	FOH Mixer
<b>Musictype</b>	Live / FOH
<b>Listener (Pax)</b>	-
<b>RMS Power</b>	-
<b>Build up manual</b>	No (-)
<b>Cargocapacity</b>	Station wagon









- ✓ 1x Behringer X32 Compact Digitalmixer
- ✓ 1x Behringer S16 Digital Stagebox
- ✓ 1x Digital Multicore 50m
- ✓ 1x WIFI Router
- ✓ 1x Tablet with X32 App



**110 €**



## 2. Light Equipment

### 2.1. Akku (rechargeable battery) LED Lamps (Ape Labs, Astera)

Ape Labs Mini V2 LED Akku lights			
<b>Type</b>	Akku LED lights	  	DMX: Wireless via W-APP Adapter
<b>Heat evolution</b>	No		 <p>Features:                      20 integrated colors / programs, controlled by WFR-1 V2 remote control for colors / programs / Sound-2-Light Mode / Dimmer / Speed.                      IP 65 Splashwater resistant</p> <p>No cables needed, complete rechargeable battery use with 10+ hours runtime</p> <p>Additional for rent for this device:                      WFR-1 V2 remote control, Power supply, W-APP BT DMX Adapter</p>
<b>DMX compatible</b>	Yes, with W-APP Adapter		
<b>Consumption of energy</b>	0 Watt		
<b>Illumination</b>	10 degrees		
<b>Type of lamp</b>	1x15 Watt CREE LED		
<b>Light output</b>	1x 15 Watt		
<b>Build up manual</b>	No (-)		
<b>Cargocapacity</b>	Compact car		



Ape Labs Maxi V2 LED Akku lights			
<b>Type</b>	Akku LED lights		DMX: Wireless via W-APP Adapter
<b>Heat evolution</b>	No	  	<p>Features:</p> <p>20 integrated colors / programs, controlled by WFR-1 V2 remote control for colors / programs / Sound-2-Light Mode / Dimmer / Speed.</p> <p>IP 65 Splashwater resistant</p> <p>No cables needed, complete rechargeable battery use with 14+ hours runtime</p> <p>Additional for rent for this device: WFR-1 V2 remote control, Power supply, W-APP BT DMX Adapter</p>
<b>DMX compatible</b>	Yes, with W-APP Adapter		
<b>Consumption of energy</b>	0 Watt		
<b>Illumination</b>	15 degrees		
<b>Type of lamp</b>	3x15 Watt CREE LED		
<b>Light output</b>	3x 15 Watt		
<b>Build up manual</b>	No (-)		
<b>Cargocapacity</b>	Compact car		

Ape Labs Tube V2 LED Akku lights			
<b>Type</b>	Akku LED lights		DMX: Wireless via W-APP Adapter
<b>Heat evolution</b>	No	  	<p>Features:</p> <p>AddOn f.e. for the Ape Labs Mini V2 Lights, for an angle of beam of 360°</p> <p>Additional for rent for this device: Mini V2</p>
<b>DMX compatible</b>	Yes, with W-APP Adapter		
<b>Consumption of energy</b>	0 Watt		
<b>Illumination</b>	15 degrees		
<b>Type of lamp</b>	3x15 Watt CREE LED		
<b>Light output</b>	3x 15 Watt		
<b>Build up manual</b>	No (-)		
<b>Cargocapacity</b>	Compact car		

Ape Labs (could be use with all Ape Labs products!) Controller and Add On`s				
<b>Type</b>	Controller and Add On`s			
<b>Heat evolution</b>	-		<b>WFR-1 V2 Fernbedienung</b> Remote control for all Ape Labs Produkte; Up to 30m range; 4 groups; remote control for color / programmes / sound-2-light mode / dimmer / speed control	<b>2,50 €</b>
<b>DMX compatible</b>	-			
<b>Consumption of energy</b>	-			
<b>Illumination</b>	-			
<b>Type of lamp</b>	-			
<b>Light output</b>	-		<b>Power supply</b> Power supply for Ape Labs; 18V 1,5A; for following products: LightCan (2-Way or 4-Way splitter) ApeLight Mini (2-Way or 4-Way splitter) ApeStick4 (2-Way splitter) ApeLight Maxi MobiLight4 Connect	<b>1 €</b>
<b>Build up manual</b>	-			
<b>Cargocapacity</b>	Compact car			
			<b>W-APP BT DMX Transceiver / Connect</b> Ape Labs W-APP / Connect Bluetooth Wireless DMX Transceiver; Controller for DMX Receiver / Sender; Bluetooth Interface for Ape Labs App for mobile devices	<b>15 €</b>

**The complete Box Set** (8 pcs. Incl. complete add on`s like Diffusordics and all remote controll)s could be found under the section:  
**Lightequipment -> Lightequipment Sets - > Set 07.0 (for only 90,- € net.)**

<b>Astera AX3 LightDrop LED Akku lights</b>	
<b>Type</b>	Akku LED lights
<b>Heat evolution</b>	No
<b>DMX compatible</b>	Yes, up to 21 channels, depends on mode
<b>Consumption of energy</b>	0 Watt
<b>Illumination</b>	13 degrees, with different diffusors
<b>Type of lamp</b>	1x15 Watt CREE LED
<b>Light output</b>	1x 15 Watt
<b>Build up manual</b>	No (-)
<b>Cargocapacity</b>	Compact car

DMX: Wireless

Features:  
The CREE LED could be shown all colors  
IP 65 Splashwater resistant





No cables needed, complete akku with up to 20 hours lighting

Additional for rent for this device:  
Diffusordiscs, Infrared remote control, Wireless DMX and tablet control, Charging case

**15 €**



<b>Astera AX3 LightDrop Diffusordics and Add On`s</b>	
<b>Type</b>	Diffusordics and Add On`s
<b>Heat evolution</b>	-
<b>DMX compatible</b>	-
<b>Consumption of energy</b>	-
<b>Illumination</b>	-
<b>Type of lamp</b>	-
<b>Light output</b>	-
<b>Build up manual</b>	-
<b>Cargocapacity</b>	Compact car

**DDSK 30°**  
Converts from 13° to 30° angle of beam

**DDSK 120°**  
Converts from 13° to 120° angle of beam

**WWDSK 46° x 13°**  
Converts from 13° to 46° x 13° angle of beam (wallwash)

**DDM 220°**  
Converts from 13° to 220° angle of beam

**AX3 / AX5 Adapterbolt**  
for Manfrotto Superclamp (to hang up AX3 devices)



**1 €**



**1 €**

**1 €**



**1 €**



**1 €**

Astera AX3 LightDrop Charging Case and Charging Add On`s				
<b>Type</b>	Charging Case and charging Add On`s		<b>Charging Case</b> (Charging- and Transportcase) for 8x Astera AX3 LightDrop Akku LED lights	<b>15 €</b>
<b>Heat evolution</b>	-			
<b>DMX compatible</b>	-			
<b>Consumption of energy</b>	-			
<b>Illumination</b>	-		<b>Chargingcable</b> for 1x Astera AX3 LightDrop Akku LED light	<b>1 €</b>
<b>Type of lamp</b>	-			
<b>Light output</b>	-			
<b>Build up manual</b>	-			
<b>Cargocapacity</b>	Compact car			

Astera (could be use with all Astera products!) Controller and Add On`s				
<b>Type</b>	Controller and Add On`s		<b>ARC1</b> Infrared remote control with 28 integrated programs	<b>10 €</b>
<b>Heat evolution</b>	-			
<b>DMX compatible</b>	-			
<b>Consumption of energy</b>	-			
<b>Illumination</b>	-		<b>ART7 Box Set</b> 1x Case 1x ART7 WDMX Transceiver 1x 3,5mm to 5 Pol (m) DMX adapter 1x Micro USB Chargingcable	<b>15 €</b>
<b>Type of lamp</b>	-			
<b>Light output</b>	-			
<b>Build up manual</b>	-			
<b>Cargocapacity</b>	Compact car			

## 2.2. Head lamps / Fluter / Chaser / PAR LED lamps / LED Bars

EUROLITE Stage Panel 16 HCL LED - BAR			
<b>Type</b>	LED Bar	DMX: In & Out	
<b>Heat evolution</b>	No	<div style="display: flex; align-items: center;">  <div> <p>Features: 6 colors: Red, green, blue, white, Amber, UltraViolett and mixed colors, as well Dimmer and Strobe; Different colors without DMX switchable; integrated mikrophone to use as stand alone effect; Infrared remote control and Eurolite QuickDMX receiver is also included.</p> </div> </div>	
<b>DMX compatible</b>	Yes, 2/3/5/6/8/11/24/32 channels		
<b>Consumption of energy</b>	Grounding-type 70 Watt		
<b>Illumination</b>	23° angle of beam		
<b>Type of lamp</b>	12 Watt HCL LED's		
<b>Light output</b>	16x 12 Watt		
<b>Build up manual</b>	No (-)		
<b>Cargocapacity</b>	Compact car		
			<p>Additional for rent for this device: For Trussing admission: Manfrotto Super Clamps</p>
			<p><b>22,5 €</b></p> 

Fluter LED 24x10 Watt - IP65			
<b>Type</b>	Fluter	DMX IP65: In & Out	
<b>Heat evolution</b>	Minimum	<div style="display: flex; align-items: center;">   <div> <p>Features: 24x RGBW Chip-LED with each 10 Watt, tiltable LED Panel for use as architecture lightning, could be used with DMX and stand alone, angle of radiation 45 degrees, weight 12,5 kg (27,55 lbs), total power consumption 250 Watt, IP 65, splashwater protected.</p> </div> </div>	
<b>DMX compatible</b>	Yes, 3/4/5/6/11 channels		
<b>Consumption of energy</b>	Grounding-type 248 Watt		
<b>Illumination</b>	Large area		
<b>Type of lamp</b>	10 Watt High Power Chip LED's		
<b>Light output</b>	24x 10 Watt		
<b>Build up manual</b>	No (-)		
<b>Cargocapacity</b>	Compact car		
			<p>Additional for rent for this device: For Trussing admission: Truss Clamps</p>
			<p><b>30 €</b></p> 

Chauvet DJ GigBar Move Plus ILS			
<b>Type</b>	LED Bar	DMX: In & Out	
<b>Heat evolution</b>	No	<div style="display: flex; align-items: center;">  <div> <p>Features: Chauvet DJ GigBar Move Plus ILS, 5-in-1 Lightsystem, 2x Movingheads (each 32 Watt), 2x RGBAW+UV Spots (each 6 Watt), 4x Strobe (each 5 Watt), 2x Derby (each 6,5 Watt), 1x Laser (class 3B, 80 mW red, 30 mW green, 80mW blue), incl. 1x Footcontrol</p> </div> </div>	
<b>DMX compatible</b>	Yes, 3/30/52 channels		
<b>Consumption of energy</b>	Grounding-type 79 Watt		
<b>Illumination</b>	17-540° angle of beam		
<b>Type of lamp</b>	LED's		
<b>Light output</b>	105 Watt		
<b>Build up manual</b>	No (-)		
<b>Cargocapacity</b>	Station wagon		
			<p>Additional for rent for this device: Stand</p>
			<p><b>60 €</b></p> 

## 2.3. Dance light effects / classic discoeffects / LED effects / Laser

LED Double Derby		
<b>Type</b>	Dancelight	<b>RedGreenBlue 3 in 1</b>
<b>Heat evolution</b>	Minimum	1x 1 Watt <b>Amber</b>
<b>DMX compatible</b>	No	Link: In & Out with XLR cables
<b>Consumption of energy</b>	Grounding-type 35 Watt	
<b>Illumination</b>	Area with beams	Features: Classical dancelight Effects, integrated Mikrophone
<b>Type of lamp</b>	3 Watt RGB LED`s, 1 Watt A/B LED`s	
<b>Light output</b>	3x 3 Watt, 1x 1 Watt	Additional for rent for this device: For Trussing admission: Truss Clamps, Switch
<b>Build up manual</b>	No (-)	
<b>Cargocapacity</b>	Compact car	



Eurolite LED D-25 Beameffect		
<b>Type</b>	Dancelight	<b>RedGreenBlueAmberWhite+UltraViolett</b>
<b>Heat evolution</b>	Minimum	6 in 1
<b>DMX compatible</b>	No	2x 18 Watt
<b>Consumption of energy</b>	Grounding-type 36 Watt	Features: Classical dancelight Effects, integrated Mikrophone, Auto mode with separate speed control
<b>Illumination</b>	Area with beams	
<b>Type of lamp</b>	2x 3 Watt each color, RGBWA+UV LED`s	Additional for rent for this device: For Trussing admission: Truss Clamps, Switch
<b>Light output</b>	2x 18 Watt	
<b>Build up manual</b>	No (-)	
<b>Cargocapacity</b>	Compact car	

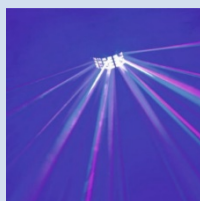

LED Derby D-400		
<b>Type</b>	Dancelight	<b>RedGreenBlueWhiteAmber 5 in 1</b>
<b>Heat evolution</b>	Minimum	Link: In & Out with XLR cables
<b>DMX compatible</b>	No	
<b>Consumption of energy</b>	Grounding-type 45 Watt	Features: Classical dancelight Effect, integrated Mikrophone
<b>Illumination</b>	Area with beams	
<b>Type of lamp</b>	3 Watt RGBWA LED`s	Additional for rent for this device: For Trussing admission: Truss Clamps, Switch
<b>Light output</b>	5x 3 Watt	
<b>Build up manual</b>	No (-)	
<b>Cargocapacity</b>	Compact car	

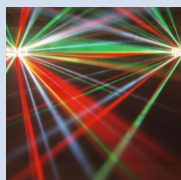

Laserworld EL-900 RGB Showlaser Quadbeam	
<b>Type</b>	Dancelight Showlaser
<b>Heat evolution</b>	Minimum
<b>DMX compatible</b>	Yes
<b>Consumption of energy</b>	Grounding-type 90 Watt
<b>Illumination</b>	Area with 4 beams
<b>Type of lamp</b>	900mW RGB DPSS Diode
<b>Light output</b>	800-900 mW
<b>Build up manual</b>	No (-)
<b>Cargocapacity</b>	Compact car



**RedGreenBlue**

Link: In & Out with XLR cables

Features:  
Classical Showlaser dancelight Effect, integrated Mikrophone

**20 €**





## 2.4. Controller (Switches, Dimmer, Lightcontroller, signal cables, Wireless DMX)

Switch			
<b>Type</b>	Light-controller		7-line On / Off Switch for switching of conventional light
<b>DMX compatible</b>	No		
<b>Needed Powerconnection</b>	Grounding-type		
<b>Signaltransfer</b>	-		
<b>Dimmer</b>	No		<b>5 €</b>
<b>Output</b>	7x Grounding-type		
<b>Power</b>	Max.3300 Watt		
<b>Build up manual</b>	No (-)		
<b>Cargocapacity</b>	Compact car		

Botex SDC-6 DMX Controller			
<b>Type</b>	Light-controller		6 channel DMX Controller
<b>DMX compatible</b>	Yes, 6 channels		1 Master Fader
<b>Needed Powerconnection</b>	Grounding-type		6 channel Fader
<b>Signaltransfer</b>	Yes, DMX		Connecting by Powerplug or by 9V battery (not included)
<b>Dimmer</b>	No		
<b>Output</b>	1x Grounding-type		1 DMX Out (3 Pol)
<b>Power</b>	-		
<b>Build up manual</b>	No (-)		
<b>Cargocapacity</b>	Compact car		<b>7,50 €</b>

Eurolite Pro Control Interface USB/DMX			
<b>Type</b>	Light-controller		DMX 512 Universal controller mit 2 DMX Universen
<b>DMX compatible</b>	Yes, 1024 channels		Minimal Systemrequirement: Windows 7 / 8 /10, <b>WITHOUT NOTEBOOK, ONLY SOFTWARE WITH USB DMX INTERFACE</b>
<b>Needed Powerconnection</b>	USB		
<b>Signaltransfer</b>	Yes, DMX		
<b>Dimmer</b>	No		
<b>Output</b>	2x DMX		1024 DMX Kanäle
<b>Power</b>	-		
<b>Build up manual</b>	No (-)		
<b>Cargocapacity</b>	Bag		<b>25 €</b>

Chauvet DJ ILS Command				
Type	Light-controller		Wireless ILS for Chauvet ILS Products	<p>Could command all Chauvet ILS products by wireless ILS signal</p> <p><b>20 €</b></p> 
DMX compatible	No			
Needed Powerconnection	USB-C			
Signaltransfer	Wireless ILS			
Dimmer	No			
Output	Wireless ILS			
Power	-			
Build up manual	No (-)			
Cargocapacity	Bag			

DMX End plug				
Type	Adapter		DMX End plug XLR 3-pol. with 110 Ohm terminating impedance	<p><b>1 €</b></p>
DMX compatible	Yes			
Needed Powerconnection	-			
Signaltransfer	DMX			
Dimmer	No			
Output	-			
Power	-			
Build up manual	No (-)			
Cargocapacity	Compact car			

DMX Adaptercable 3pol to 5 pol				
Type	Adaptercable		DMX Adaptercable 3pol (m) -> 5pol (f) DMX Adaptercable 5pol (m) -> 3pol (f)	<p><b>1 €</b></p>
DMX compatible	Yes			
Needed Powerconnection	-			
Signaltransfer	DMX			
Dimmer	No			
Output	-			
Power	-			
Build up manual	No (-)			
Cargocapacity	Compact car			

DMX Signalcable				
Type	Signalcable		3 Pol, 110 Ohm, Neutrik NC3MXX-B - NC3FXX-B & XXCR	<p>Length 2 Meter or 5 Meter</p> <p><b>1-2 €</b></p>
DMX compatible	Yes			
Needed Powerconnection	-			
Signaltransfer	DMX			
Dimmer	No			
Output	-			
Power	-			
Build up manual	No (-)			
Cargocapacity	Compact car			

DMX Signalcable				
Type	Signalcable		3 Pol, 110 Ohm, Neutrik NC3MXX-B - NC3FXX-B & XXCR  Length 10 Meter	<b>2 €</b>
DMX compatible	Yes			
Needed	-			
Powerconnection				
Signaltransfer	DMX			
Dimmer	No			
Output	-			
Power	-			
Build up manual	No (-)			
Cargocapacity	Compact car			

DMX Signalcable				
Type	Signalcable		3 Pol, 110 Ohm, Neutrik NC3MXX-B - NC3FXX-B & XXCR  Length 25 Meter	<b>5 €</b>
DMX compatible	Yes			
Needed	-			
Powerconnection				
Signaltransfer	DMX			
Dimmer	No			
Output	-			
Power	-			
Build up manual	No (-)			
Cargocapacity	Compact car			

Eurolite QuickDMX Tx / Rx (Transceiver) Transmitter / Receiver for Wireless DMX				
Type	DMX Transmitter / Receiver		DMX IN: 1x DMX OUT: 1x  (3Pin XLR) with Powersupply  Transmitter / Receiver Frequency 2,4 GhZ with 78 channels broadcast up to 400 Meter maximum at intervisibility 512 channels supported switch between transmitter and receiver at this blackboxes	<b>10 €</b>
DMX compatible	Yes			
Needed	Grounding-type			
Powerconnection				
Signaltransfer	Wireless DMX transfer			
Dimmer	No			
Output	1x DMX			
Power	-			
Build up manual	No (-)			
Cargocapacity	Compact car			

Mini DMX-Splitter				
Type	Splitter		DMX IN: 1x DMX OUT: 2x  (3Pin XLR) with 9V Powersupply	<b>3 €</b>
DMX compatible	Yes			
Needed	Grounding-type			
Powerconnection				
Signaltransfer	DMX			
Dimmer	No			
Output	2x DMX			
Power	-			
Build up manual	No (-)			
Cargocapacity	Compact car			

DMX 3 Pol-Multicore	
<b>Type</b>	Multicore
<b>DMX compatible</b>	Yes
<b>Needed</b>	-
<b>Powerconnection</b>	
<b>Signaltransfer</b>	DMX
<b>Dimmer</b>	No
<b>Output</b>	4x DMX
<b>Power</b>	-
<b>Build up manual</b>	No (-)
<b>Cargocapacity</b>	Compact car



DMX 3 Pol 4-line Multicore on cable drum with 25 Metern length

Male (Plug) to Female (cable drum)

5 €

## 2.5. Showeffects

Smoke Factory Spaceball II		
<b>Type</b>	Evaporator-fog machine	
<b>DMX compatible</b>	Yes	
<b>Needed Powerconnection</b>	Grounding-type 1000 Watt	
<b>Signaltransfer</b>	DMX (5 Pol)	
<b>Wired remote control</b>	Yes	
<b>Effect</b>	Fog cloud	
<b>Power</b>	650 Watt	
<b>Build up manual</b>	No (-)	
<b>Cargocapacity</b>	Compact car	
		<b>25 €</b>

## 2.6. AddOn (Stands, Floorstands, Standsets)

Manfrotto 126 BSU Stand		
<b>Hersteller</b>	Manfrotto	
<b>Serie</b>	BSU	
<b>Bezeichnung</b>	126	
<b>Art</b>	Stand	
<b>Anwendung</b>	Lighttechnic	
<b>Verladevolumen</b>	Compact car	
		Up to 4 Light effects (2 eachsidewith cross bar) Maximum load up to: maximum 35 kg High: maximum 3,27m, minimum 1,31m
		<b>5 €</b>

## 2.7. Light Sets

Set 01 – DJ GigBar Move Plus ILS	
<b>Type</b>	Dancelight
<b>Heat evolution</b>	Minimum - warm
<b>DMX compatible</b>	Yes, as well ILS
<b>Consumption of energy</b>	Grounding-type 248 Watt
<b>Illumination</b>	Punctual and area
<b>Type of lamp</b>	LED
<b>Light output</b>	248 Watt
<b>Build up manual</b>	No (📖)
<b>Cargocapacity</b>	Compact car



- ✓ 1x Chauvet DJ GigBar Move Plus ILS with 2x LED Derbys, 2x PAR LED Lights, 2x LED Movingheads, 1x Showlaser, 4x LED Strobe
- ✓ Incl. Footswitch
- ✓ Incl. Remote control
- ✓ 1x Stand with Baseplate
- ✓ 1x Grounding-type cable 5m

**65 €**



For only 20 € additional we offer a small Fog machine with this Set as well

Set 04.0- Ape Labs Mini V2 (8pc)Box Set	
<b>Type</b>	Dancelight / Decoration
<b>Heat evolution</b>	No
<b>DMX compatible</b>	No
<b>Consumption of energy</b>	0 Watt
<b>Illumination</b>	different
<b>Type of lamp</b>	LED RGBW
<b>Light output</b>	120 Watt
<b>Build up manual</b>	No (📖)
<b>Cargocapacity</b>	1x Small Case



- ✓ 8x Ape Labs Mini V2 Akku lights
- ✓ 1x WFR-1 V2 remote control
- ✓ 1x Transport / Charging case
- ✓ Incl. Ape Labs Connect for remote control via Smartphone
- ✓ **Only 10 minutes build up time!**

**90 €**





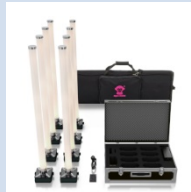

Set 04.1- Ape Labs Mini V2 & Tube V2 (8pc)Box Set	
<b>Type</b>	Dancelight / Decoration
<b>Heat evolution</b>	No
<b>DMX compatible</b>	No
<b>Consumption of energy</b>	0 Watt
<b>Illumination</b>	different
<b>Type of lamp</b>	LED RGBW
<b>Light output</b>	120 Watt
<b>Build up manual</b>	No (📖)
<b>Cargocapacity</b>	1x Small Case









- ✓ 8x Ape Labs Mini V2 Akku lights
- ✓ 8x Tube V2
- ✓ 1x WFR-1 V2 remote control
- ✓ 1x Transport / Charging case
- ✓ Incl. Ape Labs Connect for remote control via Smartphone
- ✓ 1x Nylonbag
- ✓ **Only 10 minutes build up time!**

**95 €**







Set 06.1- Ape Labs Maxi V2 (6pc)Box Set		
<b>Type</b>	Dancelight / Decoration	
<b>Heat evolution</b>	No	  
<b>DMX compatible</b>	No	
<b>Consumption of energy</b>	0 Watt	
<b>Illumination</b>	different	
<b>Type of lamp</b>	LED RGBW	
<b>Light output</b>	270 Watt	
<b>Build up manual</b>	No (📖)	
<b>Cargocapacity</b>	1x Small Case	
		<ul style="list-style-type: none"> <li>✓ 6x Ape Labs Maxi V2 Akku lights</li> <li>✓ 1x WFR-1 V2 remote control</li> <li>✓ 1x Transport / Charging case</li> <li>✓ Incl. Ape Labs Connect for remote control via Smartphone</li> <li>✓ <b>Only 10 minutes build up time!</b></li> </ul>
		<b>90 €</b> 

Set 07- Astera AX3 (8 pcs)Box Set		
<b>Type</b>	Dancelight / Decoration	
<b>Heat evolution</b>	No	  
<b>DMX compatible</b>	Yes	
<b>Consumption of energy</b>	0 Watt	
<b>Illumination</b>	different	
<b>Type of lamp</b>	LED CREE	
<b>Light output</b>	120 Watt	
<b>Build up manual</b>	No (📖)	
<b>Cargocapacity</b>	2x Small Cases	
		<ul style="list-style-type: none"> <li>✓ 8x Astera AX3 LightDrop lights</li> <li>✓ 4x Diffusordiscs for each light</li> <li>✓ 1x Charging Case for AX3 lights</li> <li>✓ 1x ARC1 Infrared remote control</li> <li>✓ 1x ART7 WDMX Controller including Tablet with Astera App and 3,5mm Jack to 5 Pol (m) DMX, Transportcase</li> <li>✓ <b>Only 15 minutes build up time!</b></li> </ul>
		<b>90 €</b> 

## 3. AV- & Mediatechnics

### 3.1. Projectors, Screens, Displays, Splitter

BenQ MH 740			
<b>Producer</b>	BenQ		Technology: DLP including HDMI/VGA- connection cable, Transport suitcase and remote control Volume: 36 dB
<b>Series</b>	MH		
<b>Decription</b>	740		
<b>Type</b>	Beamer / Projector		
<b>Ansi-Lumen</b>	4000		
<b>Solution</b>	Full HD 1920 x 1080		
<b>Inputs</b>	F-Bas, VGA, DVI, HDMI		
<b>Contrastrate</b>	11.000:1		
<b>Cargocapacity</b>	Compact car		
			<b>50 €</b>

Epson EB-810E Ultrashortdistanceprojector			
<b>Producer</b>	Epson		Technology: Laser including HDMI- connection cable, Transport suitcase and remote control Volume: 35 dB  Ultrashort distance Projector
<b>Series</b>	EB		
<b>Decription</b>	810E		
<b>Type</b>	Beamer / Projektor		
<b>Ansi-Lumen</b>	5000		
<b>Solution</b>	Full HD 1920 x 1080		
<b>Inputs</b>	HDMI		
<b>Contrastrate</b>	2.500.000:1		
<b>Cargocapacity</b>	Compact car		
			<b>100 €</b>

Logitech R400 Presenter			
<b>Producer</b>	Logitech		Logitech R400 Presenter for conferencing with Laserpointer
<b>Series</b>	R400		
<b>Decription</b>	Presenter		
<b>Type</b>	Presenter		
<b>Cargocapacity</b>	Bag		
			<b>8 €</b>

Short Projektor hold up for trussing			
<b>Producer</b>	-		Mounting connection with screws on the projector, on the other side mounted with a 50mm clamp for hold it up on a truss system
<b>Series</b>	-		
<b>Decription</b>	Procektor- hold up		
<b>Type</b>	Rigging		
<b>Cargocapacity</b>	Compact car		
			<b>5 €</b>

<b>Projektor hold up for stands</b>				
<b>Producer</b>	-		Adapterplate for projectors, the admission gets trough loudspeakerflansch to pipe cross-section dimension 35 mm, Dimensions: 420 x 380 mm, maximum central load: 35 kg	<b>5 €</b>
<b>Series</b>	-			
<b>Decription</b>	Projector-hold up			
<b>Type</b>	Adapterplate			
<b>Cargocapacity</b>	Compact car			
			To connect the adapterplate on lightstands, you will need the adapterbolt K&M 24518!	

<b>Gravity SP 2332 EXT B - Distancepiece</b>				
<b>Producer</b>	-		50 cm length, made of steel, M20-wind (1 x male, 1 x female)	<b>2 €</b>
<b>Series</b>	-			
<b>Decription</b>	For Projector-hold up			
<b>Type</b>	Adapterpiece			
<b>Cargocapacity</b>	Compact car			

<b>K&amp;M 24518 Adapterbolt</b>				
<b>Producer</b>	K&M		Adapterbolt from light stands by TV-gudgeon to 20/loudspeakerstandflansch, 35mm cross section dimension, with inner winding M10 x 35mm, made of steel, nickelized, Ø 28/35mm, L: 215 mm	<b>1 €</b>
<b>Series</b>	-			
<b>Decription</b>	24518			
<b>Type</b>	Adapter			
<b>Cargocapacity</b>	Compact car			

<b>Bordered screen Stumpfl Monoblox</b>				
<b>Producer</b>	AV Stumpfl		Easy handle bordered screen display Stumpfl Monoblox (front-projection) with single leaf aluminiumborder, dimensions of the screen including the border 2,86m x 1,70m	<b>60 €</b>
<b>Series</b>	Monoblox 32			
<b>Decription</b>	Bordered screen			
<b>Projection</b>	Front-projection			
<b>Projections-dimension in m</b>	2,66 x 1,50			
<b>Width-to-high ratio</b>	16:9			
<b>Cargocapacity</b>	Compact car			

<b>Bordered screen Stumpfl Monoblox</b>				
<b>Producer</b>	AV Stumpfl		Easy handle bordered screen display Stumpfl Monoblox (front-projection) with single leaf aluminiumborder, dimensions of the screen including the border 3,86m x 2,26m	<b>110 €</b>
<b>Series</b>	Monoblox 32			
<b>Decription</b>	Bordered screen			
<b>Projection</b>	Front-projection			
<b>Projections-dimension in m</b>	3,66 x 2,06			
<b>Width-to-high ratio</b>	16:9			
<b>Cargocapacity</b>	Station Wagon			

Rear projection cloth for bordered screen display Stumpfl	
<b>Producer</b>	AV Stumpfl
<b>Series</b>	Monoblox 32
<b>Decription</b>	Rahmen- leinwand Tuch
<b>Projection</b>	Rückprojektion
<b>Projections- dimension in m</b>	3,66 x 2,06
<b>Width-to-high ratio</b>	16:9
<b>Cargocapacity</b>	-

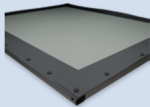

Added on rear projection cloth for a easy handle Stumpfl Monoblox with single leaf aluminiumborder, dimensions of the screen including the border 3,86m x 2,26m

**30 €**

EasyFly for Bordered screen Stumpfl Monoblox 32 series	
<b>Producer</b>	AV Stumpfl
<b>Series</b>	Monoblox 32
<b>Decription</b>	EasyFly 32
<b>Projection</b>	-
<b>Projections- dimension in m</b>	-
<b>Width-to-high ratio</b>	-
<b>Cargocapacity</b>	-



Holding points for the Stumpfl Monoblox 32 system, that make it possible, to get the screen hinged up

**5 €**

24" Monitor	
<b>Producer</b>	-
<b>Series</b>	-
<b>Decription</b>	24" Monitor
<b>Projection</b>	-
<b>Projections- dimension in m</b>	0,53 x 0,30
<b>Width-to-high ratio</b>	16:9
<b>Cargocapacity</b>	Compact Car



Easy handable 24" Monitor

Screen diagonal:  
0,61 m

**15 €**

VGA Signalcable	
<b>Type</b>	Signalcable
<b>F-Bas</b>	No
<b>S-Video</b>	No
<b>VGA</b>	Yes
<b>DVI</b>	No
<b>HDMI</b>	No
<b>Apple</b>	No
<b>Build up manual</b>	No (-)
<b>Cargocapacity</b>	Bag



Length: 10 Meter

VGA cable for the connection of PCs/Notebooks to a projector

**5 €**

VGA Signalcable	
<b>Type</b>	Signalcable
<b>F-Bas</b>	No
<b>S-Video</b>	No
<b>VGA</b>	Ja
<b>DVI</b>	No
<b>HDMI</b>	No
<b>Apple</b>	No
<b>Build up manual</b>	No (-)
<b>Cargocapacity</b>	Bag



Length: 20 Meter

VGA cable for the connection of PCs/Notebooks to a projector

**5 €**

HDMI Signalcable UHD 4K		
<b>Type</b>	Signalcable	 Length: 1 Meter  HDMI cable for the connection of PCs/Notebooks on a HDMI Beamer  <div style="text-align: right;"><b>3 €</b></div>
<b>F-Bas</b>	No	
<b>S-Video</b>	No	
<b>VGA</b>	No	
<b>DVI</b>	No	
<b>HDMI</b>	Yes	
<b>Apple</b>	No	
<b>Build up manual</b>	No (-)	
<b>Cargocapacity</b>	Bag	

HDMI Signalcable UHD 4K		
<b>Type</b>	Signalcable	 Length: 10 Meter  HDMI cable for the connection of PCs/Notebooks on a HDMI Beamer  <div style="text-align: right;"><b>6 €</b></div>
<b>F-Bas</b>	No	
<b>S-Video</b>	No	
<b>VGA</b>	No	
<b>DVI</b>	No	
<b>HDMI</b>	Yes	
<b>Apple</b>	No	
<b>Build up manual</b>	No (-)	
<b>Cargocapacity</b>	Bag	

HDMI UHD 4K – Connector		
<b>Type</b>	Connector	 Adapter for extension of 2 HDMI UHD 4K cables  <div style="text-align: right;"><b>5 €</b></div>
<b>F-Bas</b>	No	
<b>S-Video</b>	No	
<b>VGA</b>	No	
<b>DVI</b>	No	
<b>HDMI</b>	Yes	
<b>Apple</b>	No	
<b>Build up manual</b>	No (-)	
<b>Cargocapacity</b>	Bag	

HDMI UHD 4K – Splitter 1 HDMI UHD 4K signal to 2 HDMI UHD 4K signals		
<b>Type</b>	Splitter	 HDMI UHD 4K Splitter from one HDMI UHD 4K to two HDMI UHD 4K signal ways  <div style="text-align: right;"><b>5 €</b></div>
<b>F-Bas</b>	No	
<b>S-Video</b>	No	
<b>VGA</b>	No	
<b>DVI</b>	No	
<b>HDMI</b>	Yes	
<b>Apple</b>	No	
<b>Build up manual</b>	No (-)	
<b>Cargocapacity</b>	Bag	

HDMI UHD 4K – Splitter 1 HDMI UHD 4K signal to 4 HDMI UHD 4K signals		
<b>Type</b>	Splitter	 HDMI UHD 4K Splitter from one HDMI UHD 4K to four HDMI UHD 4K signal ways  <div style="text-align: right;"><b>5 €</b></div>
<b>F-Bas</b>	No	
<b>S-Video</b>	No	
<b>VGA</b>	No	
<b>DVI</b>	No	
<b>HDMI</b>	Yes	
<b>Apple</b>	No	
<b>Build up manual</b>	No (-)	
<b>Cargocapacity</b>	Bag	

HDMI Audio Extractor		
Type	HDMI Audio Extractor	HDMI Audio Extractor
F-Bas	No	<div style="display: flex; align-items: center;">  <div> <p>4K HDMI (f) IN &amp; OUT</p> <p>Audio Signal OUT: SPDIF (Optical) / RCA Stereo</p> <p>Audio Signal Options: Pass (by HDMI), 2 channels RCA, 5.1 channels optical (SPDIF)</p> </div> </div>
S-Video	No	
VGA	No	
DVI	No	
HDMI	Yes	
Apple	No	
Build up manual	No (-)	
Cargocapacity	Bag	
		<b>5 €</b>

WLAN Router		
Type	WLAN Router	WLAN Router including Power Adapter, for ex. To connect Smart TV's with Wifi to show pictures and videos from your mobile device (for ex. App "Tubio")
F-Bas	No	<div style="display: flex; align-items: center;">  <div> <p>5 €</p> </div> </div>
S-Video	No	
VGA	No	
DVI	No	
HDMI	No	
Apple	No	
Build up manual	No (-)	
Cargocapacity	Bag	

VGA - Connector		
Type	Connector	Adapter for extension of 2 S-VGA cables
F-Bas	No	<div style="display: flex; align-items: center;">  <div> <p>1 €</p> </div> </div>
S-Video	No	
VGA	Yes	
DVI	No	
HDMI	No	
Apple	No	
Build up manual	No (-)	
Cargocapacity	Bag	

### 3.2. AV- & Mediatechnics Sets

Set 03 - Presentationsset with loudspeaker and large bordered screen			
<b>Projector / Beamer</b>	Yes		
<b>Screen</b>	Yes		
<b>Screen width-to-high ratio</b>	16:9		
<b>Screen in m</b>	2,86 x 1,70		
<b>Ansi-Lumen</b>	4000		
<b>Solution</b>	Full HD 1920 x 1080		
<b>Inputs</b>	F-Bas, VGA		
<b>Contrastrate</b>	11:000:1		
<b>Cargocapacity</b>	Stationwagon		
		<ul style="list-style-type: none"> <li>✓ 1x Bordered Screen Display 2,86m x 1,70m</li> <li>✓ 1x BenQ MH740 Projector incl. transportcase, remotecontrol and VGA/HDMI cable</li> <li>✓ 1x Activemonitor</li> <li>✓ 1x Projectorplate with adapterbolt for stands</li> <li>✓ 1x stand for Projectorplate</li> <li>✓ 1x Cinch cable 5 Meter</li> <li>✓ 1x grounding-type cable 10 Meter</li> <li>✓ 1x grounding-type cable 5 Meter</li> <li>✓ 1x grounding-type cable 3-way</li> </ul>	<b>130 €</b>

### 3.3. PhotoBox / FotoBox / PhotoBooth

PhotoBox / PhotoBooth - Starter Set			
<b>To use by</b>	Your own / Touchscreen		
<b>Needed Power</b>	600 Watt		
<b>Pictures on</b>	USB Stick		
<b>Needed space</b>	~ 1m x 1m	<ul style="list-style-type: none"> <li>✓ 1x PhotoBox</li> <li>✓ 1x Loudspeaker stand</li> <li>✓ 1x PhotoBox Flash</li> <li>✓ 1x USB Stick (This Stick with all the taken pictures is yours after the event)</li> </ul>	<b>177 €</b>
<b>Cargocapacity</b>	Compact car		

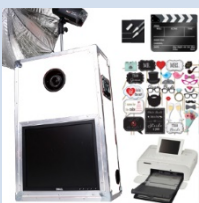
PhotoBox / PhotoBooth - Wedding Set			
<b>To use by</b>	Your own / Touchscreen		
<b>Needed Power</b>	600 Watt		
<b>Pictures on</b>	USB Stick, Printer, Gallery Upload		
<b>Needed space</b>	~ 1m x 1m	<ul style="list-style-type: none"> <li>✓ 1x PhotoBox</li> <li>✓ 1x Loudspeaker stand</li> <li>✓ 1x PhotoBox Flash</li> <li>✓ 1x USB Stick (This Stick with all the taken pictures is yours after the event)</li> <li>✓ Printer (incl. 216 prints)</li> <li>✓ Accessories Box Wedding</li> <li>✓ Directors movie hatch with marker</li> <li>✓ Picturegallery Upload after the event for your guests</li> </ul>	<b>249 €</b>
<b>Cargocapacity</b>	Compact car	<p>Additional 108 prints could be added in advance for 29,- € net.</p>	

### 3.4. Livestream & Broadcasting, Videocameras, Video Capturing

Panasonic 4K Camcorder HC-VXF999				
<b>Producer</b>	Panasonic		<ul style="list-style-type: none"> <li>✓ Panasonic 4K Ultra HD-Camcorder HC-VXF999</li> <li>✓ LEICA DICOMAR lense with 20x optical zoom</li> <li>✓ 5-axis picturestabilisator O.I.S.+</li> <li>✓ Pictoresensor: 18.91Mpx</li> <li>✓ 25p</li> <li>✓ 4K Video</li> <li>✓ Max Resolution: 3840 x 2160 Pixels (4K/UHD)</li> <li>✓ WLan</li> <li>✓ SD card 64 GB</li> </ul>	
<b>Series</b>	HC			<b>65 €</b>
<b>Description</b>	VXF999			
<b>Resolution</b>	3840 x 2160 Pixels (4K/UHD)			

HDMI (m) to Mini HDMI (m) Adaptercable			
<b>Side 1</b>	HDMI (male)		<ul style="list-style-type: none"> <li>✓ HDMI (m) to Mini HDMI (m) Adaptercable</li> </ul>
<b>Side 2</b>	Mini HDMI (male)		

HDMI (m) to Micro HDMI (m) Adaptercable			
<b>Side 1</b>	HDMI (male)		<ul style="list-style-type: none"> <li>✓ HDMI (m) to Micro HDMI (m) Adaptercable</li> </ul>
<b>Side 2</b>	Micro HDMI (male)		

USB (m) to USB (f) cable			
<b>Side 1</b>	USB (male)		<ul style="list-style-type: none"> <li>✓ USB (m) to USB (f) cable</li> </ul>
<b>Side 2</b>	USB (female)		

## 4. Rigging (Trussing & Addon`s)

### 4.1. Lifting accessories (Hooks, Shackle, Robes, Safety harness, TV gudgeon and so on...)

TV-gudgeon			
<b>Description</b>	TV-gudgeon		For mounting lamps on a stand
<b>Range of use</b>	Lighttechnics		<b>1 €</b>
<b>Permission till</b>	-		
<b>Cargocapacity</b>	Compact car		

Truss Clamp small			
<b>Description</b>	Truss Clamp		For hanging up lightequipment and so on
<b>Range of use</b>	Rigging of lighttechnics		<b>1 €</b>
<b>Permission till</b>	100 kg		
<b>Cargocapacity</b>	Compact car		

Manfrotto Superclamp FTC			
<b>Description</b>	Superclamp		For hanging up lightequipment and so on
<b>Range of use</b>	Rigging of lighttechnics		<b>1 €</b>
<b>Permission till</b>	15 kg		
<b>Cargocapacity</b>	Compact car		

Mounting system: hexagonal 5/8" Socket, as well 1/4" and 2 x M5 winding (female) TÜV & GS proved, for pipes or flood relieves structures between 13 - 55 mm

Truss Clamp withpicot - small			
<b>Description</b>	Truss Clamp		For hanging up mirrorballsor shakles on the picot
<b>Range of use</b>	Rigging		<b>1 €</b>
<b>Permission till</b>	250 kg		
<b>Cargocapacity</b>	Compact car		

Truss Clamp with picot - large			
<b>Description</b>	Truss Clamp		For hanging up mirrorballsor shakles on the picot
<b>Range of use</b>	Rigging		<b>1 €</b>
<b>Permission till</b>	500 kg		
<b>Cargocapacity</b>	Compact car		

Trigger Clamp		
<b>Description</b>	Trigger Clamp	
<b>Range of use</b>	Rigging of lighttechnics	
<b>Permission till</b>	120 kg	
<b>Cargocapacity</b>	Compact car	
		<b>1 €</b>

Trussaufnehmer double rotateable		
<b>Description</b>	Trigger Clamp	
<b>Range of use</b>	Rigging of lighttechnics	
<b>Permission till</b>	120 kg	
<b>Cargocapacity</b>	Compact car	
		<b>1 €</b>

Tension belt		
<b>Description</b>	Tension belt	
<b>Range of use</b>	-	
<b>Permission till</b>	-	
<b>Cargocapacity</b>	Compact car	
		<b>1 €</b>

Shakle middle (bluemottled)		
<b>Description</b>	Shakle	
<b>Range of use</b>	Rigging	
<b>Permission till</b>	2 Tons	
<b>Cargocapacity</b>	Compact car	
		<b>1 €</b>

Shakle large (yellowmottled)		
<b>Description</b>	Shakle	
<b>Range of use</b>	Rigging	
<b>Permission till</b>	3,25 Tons	
<b>Cargocapacity</b>	Compact car	
		<b>1 €</b>

Round sling 1,00 Meter (black) / Steelflex		
<b>Description</b>	Aeroquip	
<b>Range of use</b>	Rigging	
<b>Permission till</b>	1 Ton	
<b>Cargocapacity</b>	Compact car	
		<b>2 €</b>

## 4.2. Trussing (Global Truss)

Global Truss - Trussing - F31 (1 Punkt) with 3 Meter length			
<b>Producer</b>	Global Truss		On request with incl. 1 cone-shaped connection, 1 bolt and 2 safety splints  <b>7 €</b>
<b>Series</b>	F31		
<b>Description</b>	3,00m		
<b>Net weight</b>	2,00 kg		
<b>Cargocapacity</b>	Transporter		

### 4.3. Stage materials (Cable mattress, tents, and so on...)

Cable mattress		
<b>Producer</b>	-	Black rubber / finegroovesmattress
<b>Series</b>	-	
<b>Description</b>	Feinriefen-kabelmatte	
<b>Length</b>	2,00m	
<b>Width</b>	0,50m	
<b>Cargocapacity</b>	Compact car	
		<b>2 €</b>

Defender Mini Cable bridge		
<b>Producer</b>	-	Length: 100 cm
<b>Series</b>	-	Width: 29 cm
<b>Description</b>	Feinriefen-kabelmatte	High: 4.8 cm
<b>Length</b>	1,00m	3 channels
<b>Width</b>	0,29m	Max load: ~ 2 t on 20cm x 20cm
<b>Cargocapacity</b>	Compact car	Weight: 5 kg
		<b>5 €</b>

Webbing canvas		
<b>Producer</b>	-	Blue
<b>Series</b>	-	With integrated picots
<b>Description</b>	Webbing canvas	
<b>Length</b>	4,00m	
<b>Width</b>	6,00m	
<b>Cargocapacity</b>	Compact car	

HoldOn Clip		
<b>Producer</b>	Stairville	Best device to fix a blank molleton
<b>Series</b>	-	
<b>Description</b>	HoldOn Clip	
<b>Length</b>	5,50m	
<b>Width</b>	2,00m	
<b>Cargocapacity</b>	Compact car	
		<b>0,50 €</b>

Molleton 1m x 3m		
<b>Producer</b>	Stairville	Molleton for ex. To use as frontcover for nivtec systemplatforms
<b>Series</b>	-	
<b>Description</b>	Molton	
<b>Length</b>	1,00 m	
<b>Width</b>	3,00 m	
<b>Cargocapacity</b>	Compact car	
		<b>5 €</b>

Clamping fixture	
<b>Producer</b>	Stairville
<b>Series</b>	-
<b>Description</b>	Clamping fixture
<b>Length</b>	5,50m
<b>Width</b>	2,00m
<b>Cargocapacity</b>	Compact car



Clamping fixture 25cm to get a holdon clip to trussing

**0,50 €**

Europalette plastic	
<b>Producer</b>	-
<b>Series</b>	-
<b>Description</b>	Europallet
<b>Length</b>	1,20m
<b>Width</b>	0,80m
<b>Cargocapacity</b>	Van / Transporter



Stable underground for Subwoofer in Outdoor areas

**5 €**

Foldable Pavillon (tent) black with 3m x 3m	
<b>Producer</b>	StabileZelte
<b>Series</b>	Professional
<b>Description</b>	Foldable Pavillon
<b>Length</b>	3,00m
<b>Width</b>	3,00m
<b>Cargocapacity</b>	Stationwagon



Foldable Pavillion (tent) in black

3m x 3m

1,90m up to 2,10m passing height

3,10m up to 3,30m firstheight

2 side walls closed

2x side walls with 1,50m door

4x steelweights

2x transport bags

**50 €**

For example to use as FOH tent

## 4.4. Systemplattform (Nivtec)

<b>Nivtec Systemplattform 1m x 0,5m</b>	
<b>Producer</b>	Nivtec
<b>Series</b>	System- plattform
<b>Description</b>	111 06 0
<b>Length</b>	1,00m
<b>Width</b>	0,50m
<b>Cargocapacity</b>	Compact car / Stationwagon
	
Maximum load 750 kg/qm Color: dark brown Weight: 12 kg Including 4 Nivtec telescope base, 0,60m till 1,00m	
<b>7,50 €</b>	

<b>Molleton-Skirting (black)</b>	
<b>Producer</b>	Stairville
<b>Series</b>	-
<b>Description</b>	Molleton
<b>Length</b>	3,00m
<b>Width</b>	1,00m
<b>Cargocapacity</b>	Compact car
	
Stagemolleton (black) with B1 (heavy flameable leaned to DIN 4102) and 300 Gramm each m <sup>2</sup>	
<b>5 €</b>	

<b>Nivtec Telescopebase</b>	
<b>Producer</b>	Nivtec
<b>Series</b>	Telescope- base
<b>Description</b>	203 02 1
<b>Length</b>	0,60m - 1,00m
<b>Width</b>	-
<b>Cargocapacity</b>	Compact car
	
Able to be fixed at variable hight points	
<b>1,50 €</b>	

## 5. Electricity Power, Energy & Generators

### 5.1. Three-phase current power (CEE) & Grounding-types (Three-phase current-, Grounding-types -, Performance load Multicorecable-, cables & distributors)

16 A CEE (three-phase current power) distributorsmall			
<b>Input 16 A CEE</b>	Yes, 1x		Distributor CEE (Three-phase current power)
<b>Output grounding-type</b>	Yes, 3x		
<b>Cablelength</b>	circa 1,5m		
<b>Cargocapacity</b>	Compact car		
			<b>10 €</b>

16 A CEE (three-phase current power) distributor			
<b>Input 16 A CEE</b>	Yes, 1x		Distributor CEE (Three-phase current power)
<b>Ausgang grounding-type</b>	Yes, 9x		
<b>Cablelength</b>	circa 3m		
<b>Cargocapacity</b>	Compact car		
			<b>10 €</b>

32 A CEE (three-phase current power) distributor			
<b>Input 32 A CEE</b>	Yes, 1x		Distributor CEE (Three-phase current power)
<b>Output 16 A CEE</b>	Yes, 2x		
<b>Output grounding-type</b>	Yes, 6x		
<b>Cablelength</b>	circa3m		
<b>Cargocapacity</b>	Compact car		
			<b>15 €</b>

63 A CEE (three-phase current power) distributor			
<b>Input 63 A CEE</b>	Yes, 1x		Distributor CEE (Three-phase current power)
<b>Output 32 A CEE</b>	Yes, 2x		
<b>Output 16 A CEE</b>	Yes, 2x		
<b>Output grounding-type</b>	Yes, 6x		
<b>Cablelength</b>	circa 5m		
<b>Cargocapacity</b>	Compact car		
			<b>30 €</b>

16 A CEE (three-phase current power) distributor for Truss mounting		
<b>Input 16 A CEE</b>	Yes, 1x	 Distributor CEE AP/LD 626 (Three-phase current power)
<b>Output 16 A CEE</b>	Yes, 1x	
<b>Output grounding-type</b>	Yes, 3x	
<b>Cablelength</b>	circa 1,5m	
<b>Cargocapacity</b>	Compact car	
		<b>10 €</b>

32 A CEE (three-phase current power) distributor for Truss mounting		
<b>Input 32 A CEE</b>	Yes, 1x	 Distributor CEE AP/LD 648, 6x Protection automatics (Three-phase current power)
<b>Output 16 A CEE</b>	Yes, 1x	
<b>Output grounding-type</b>	Yes, 3x	
<b>Cablelength</b>	circa 1,5m	
<b>Cargocapacity</b>	Compact car	
		<b>15 €</b>

16 A CEE (three-phase current power) cable		
<b>Input 16 A CEE</b>	Yes, 1x	 CEE cable (Three-phase current power)
<b>Output 16 A CEE</b>	Yes, 1x	
<b>Cablelength</b>	10m, 15m, 20m, 25m	
<b>Cargocapacity</b>	Compact car	
		<b>3-5 €</b>

16 A CEE(three-phase current power) cabledrum		
<b>Input 16 A CEE</b>	Yes, 1x	 CEE Cable drum (Three-phase current power)
<b>Output 16 A CEE</b>	Yes, 1x	
<b>Output grounding-type</b>	Yes, 2x	
<b>Cablelength</b>	25m	
<b>Cargocapacity</b>	Compact car	
		<b>5 €</b>

32 A CEE (three-phase current power) cable		
<b>Input 32 A CEE</b>	Yes, 1x	 CEE cable (Three-phase current power)
<b>Output 32 A CEE</b>	Yes, 1x	
<b>Cablelength</b>	10m, 15m, 20m, 25m	
<b>Cargocapacity</b>	Compact car	
		<b>5-8 €</b>

63 A CEE (three-phase current power) cable		
<b>Input 63 A CEE</b>	Yes, 1x	 CEE cable (Three-phase current power)
<b>Output 63 A CEE</b>	Yes, 1x	
<b>Cablelength</b>	5m	
<b>Cargocapacity</b>	Compact car	
		<b>5 €</b>

32 A CEE to 16 A CEE Adaptercable				
<b>Input 32 A CEE</b>	Yes, 1x		Adaptercable 32A CEE (Three-phase current power) hitch to 16A CEE (Three-phase current power) plug	<b>3 €</b>
<b>Output 16 A CEE</b>	Yes, 1x			
<b>Cablelength</b>	1m			
<b>Cargocapacity</b>	Compact car			

63 A CEE to 32 A CEE Adaptercable				
<b>Input 63 A CEE</b>	Yes, 1x		Adaptercable 63A CEE (Three-phase current power) hitch to 32A CEE (Three-phase current power) plug	<b>3 €</b>
<b>Output 32 A CEE</b>	Yes, 1x			
<b>Cablelength</b>	1m			
<b>Cargocapacity</b>	Compact car			

Grounding-type distributor				
<b>Input grounding-type</b>	Yes, 1x		3-line grounding-type distributor	<b>0,50 €</b>
<b>Output grounding-type</b>	Yes, 3x or 6x			
<b>Cablelength</b>	1m			
<b>Cargocapacity</b>	Compact car			

Grounding-type cable 3m with 3-Way distributor				
<b>Input grounding-type</b>	Yes, 1x		3 Meter with 3-way distributor	<b>1 €</b>
<b>Output grounding-type</b>	Yes, 1x			
<b>Cablelength</b>	3m			
<b>Cargocapacity</b>	Compact car			

Grounding-type cable				
<b>Input grounding-type</b>	Yes, 1x		Grounding-type cable	<b>1-3 €</b>
<b>Output grounding-type</b>	Yes, 1x			
<b>Cablelength</b>	5m, 10m, 25m			
<b>Cargocapacity</b>	Compact car			

## 6. Tools

### 6.1. Tools

Tools Case			
<b>Type</b>	Tools		Combination pliers Wrench Lever drill Hexagonal key wrench
<b>Cargocapacity</b>	Compact car		

DB Analyzer			
<b>Type</b>	db Analyzer		Gauging the loudness in DB (A) and DB(C)
<b>Cargocapacity</b>	Bag		

DB-measure instrument with db (A) Leq			
<b>Type</b>	db Analyzer		Dezibel measure instrument  db(A) / db(B) db(C) with IEC DIN 651  Lmax and Ln %  Lp and Leq db (A) weighting  Leq Intervall: Seconds: 1 / Minutes: 1, 5, 10, 15, 30 / hours: 1, 8, 24  As well 30 groups to save for measure weights  94 db calibrated
<b>Cargocapacity</b>	Bag		

Cable Analyzer			
<b>Type</b>	Analyzer		Gauging your audio cables: Cinch; 6,3mm Jack; SpeakOn; XLR
<b>Cargocapacity</b>	Bag		

Voltmeter			
<b>Type</b>	Analyzer		Standard Voltmeter
<b>Cargocapacity</b>	Bag		

## 7. Service

### 7.1. Technicians, DJs, long term rentals

<b>Technician</b>			
<b>Counting</b>	Each inchoated hour	Delivery and pick up service form Equipment, installation and dismantling of audio equipment, installation and dismantling of light equipment, installation and dismantling of av- & media equipment	<b>Starting from 39 €</b>
<b>Type</b>	Adeptedworker		

<b>Long term rentals</b>			
<b>Counting</b>	Individual	Long term rentals of light-, audio-, and AV- & Mediatechnics for convenient conditions	<b>On request</b>
<b>Type</b>	Special rental prices for Clubs and Bars		